



BIO.design[®]

More Than A Pool

**PROJECT
CATALOGUE**

Bio.design Shapes

Forme Bio.design | Formas Bio.design | Formes Bio.design | Formen Bio.design



BD-01

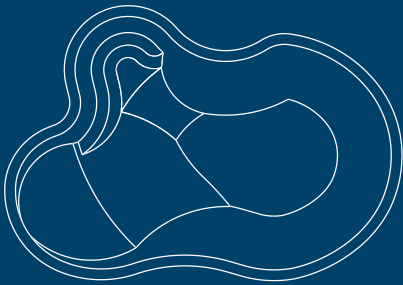

BD-02

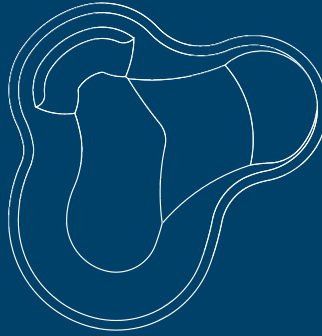

BD-03

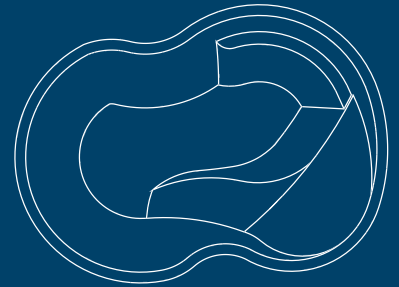

BD-04

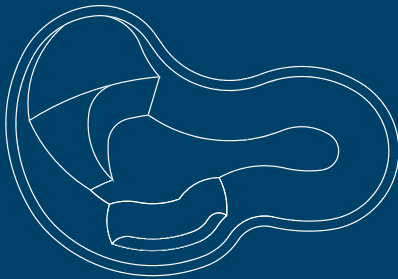

BD-05

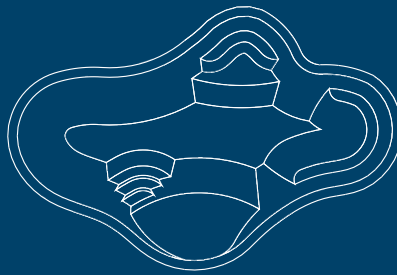

BD-06

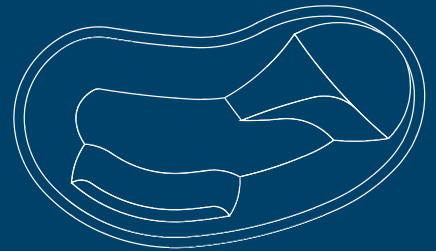

BD-07

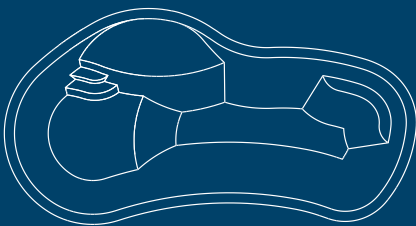

BD-08

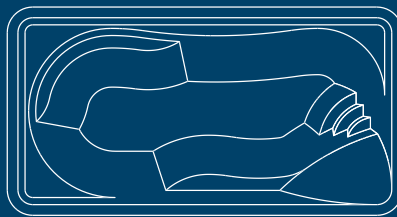

BD-09

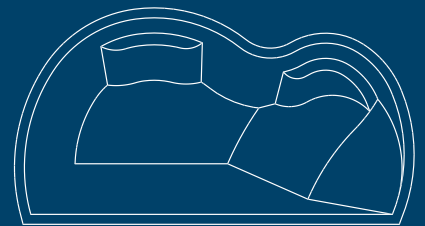

BD-10

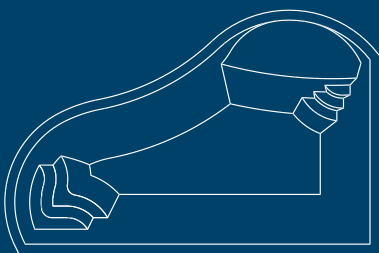

BD-11

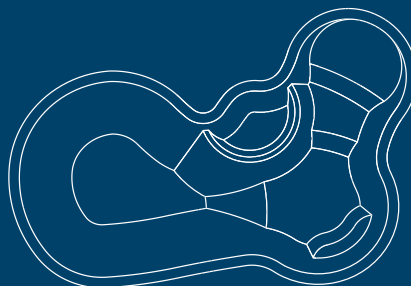

BD-12



Shaping your Bio.design

Progettare Bio.design | Diseñar Bio.design | Dessinez Bio.design | Gestaltung Bio.design

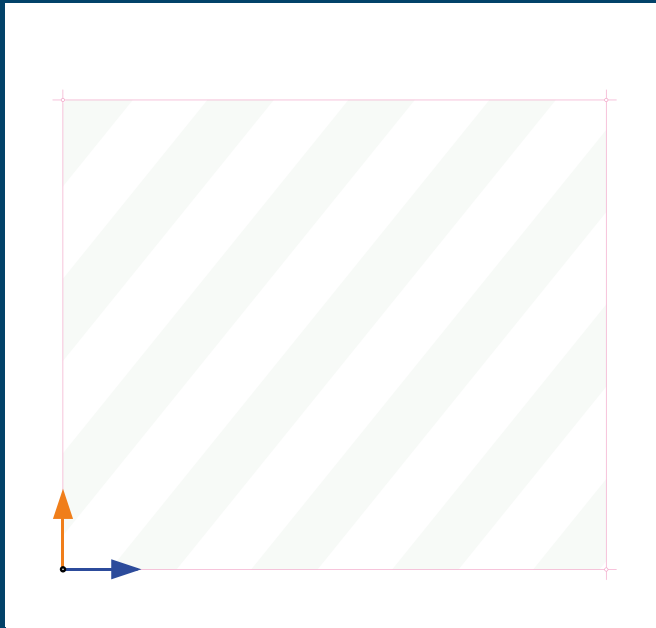

[EN] Inspection: Check the place where to contextualize and build the pool. In this first phase it is extremely important to decide where to place monoliths, expansion joints, choice of natural coating Bio.design, and orientation of the pool to the sun.

[IT] Sopralluogo: Verifica il luogo in cui contestualizzare e costruire la piscina. In questa prima fase è estremamente importante decidere dove posizionare i monoliti, i giunti di dilatazione, la scelta dei rivestimenti naturali Bio.design e individuare l'orientamento del sole.

[ES] Inspección: Compruebe el lugar donde contextualizar y construir la piscina. En esta primera fase es de extrema importancia decidir dónde colocar los monolitos, las juntas de dilatación, la elección del revestimiento natural Bio.design, y la orientación de la piscina con respecto al sol.

[FR] Inspection : Vérifiez l'endroit où contextualiser et réaliser la piscine. Dans cette première phase, il est extrêmement important de décider où placer les monolithes, les joints de dilatation, le choix du revêtement naturel Bio.design, l'orientation de la piscine par rapport au soleil.

[DE] Oben: Überprüfen Sie den Ort, wo Sie den Pool kontextualisieren und bauen. In dieser ersten Phase ist es äußerst wichtig zu entscheiden, wo Monolithe, Dehnfugen, die Wahl der natürlichen Beschichtung Bio.design, Ausrichtung des Pools in Bezug auf die Sonne.

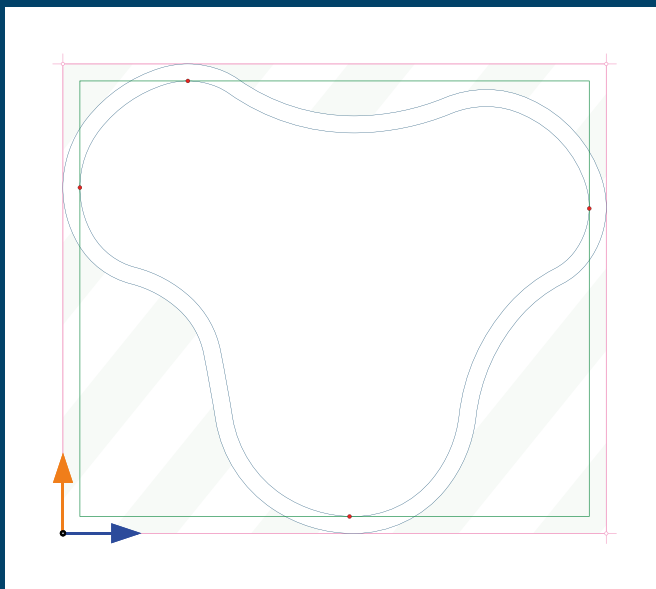

[EN] Shape: Decided the area and location of our pool, it's time to choose one of our shapes or perhaps design a fully customized one. At this stage we can also decide the maximum depth.

[IT] Forma: Decisa l'area e la posizione della nostra piscina, è venuto il momento di scegliere una delle nostre forme o eventualmente progettare una completamente personalizzata. In questa fase è possibile definire anche la profondità massima.

[ES] Forma: Decidido el área y la ubicación de nuestra piscina, ha llegado el momento de elegir una de nuestras formas o eventualmente diseñar una completamente personalizada. En esta etapa también podemos decidir la profundidad máxima.

[FR] Forme : Après avoir déterminé la zone et l'emplacement de notre piscine, il est temps de choisir l'une de nos formes ou éventuellement d'en concevoir une entièrement personnalisée. À ce stade, nous pouvons également décider de la profondeur maximale.

[DE] Form: Nachdem wir uns für den Bereich und die Lage unseres Swimmingpools entschieden haben, ist es an der Zeit, eine unserer Formen zu wählen oder möglicherweise eine völlig individuelle zu entwerfen. In diesem Stadium können wir auch die maximale Tiefe bestimmen.

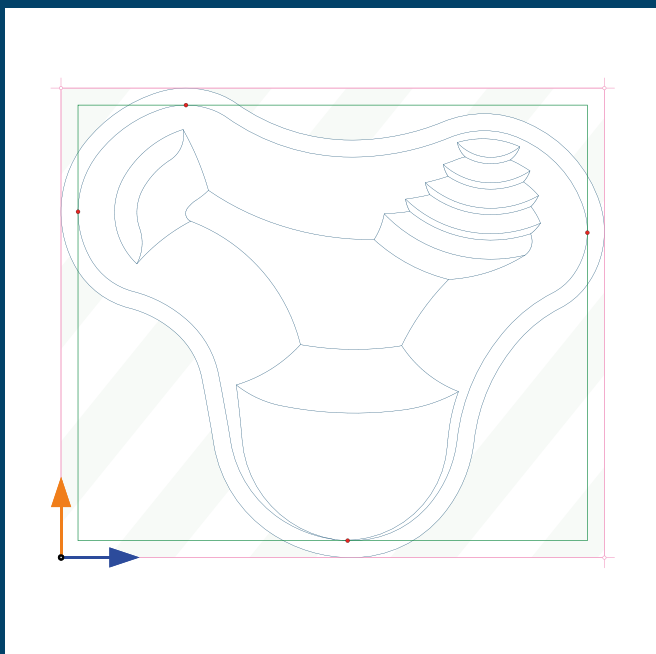

[EN] Modelling: Let's decide now how to shape the interior. Let's not forget the entrances to enter or exit our pool. Decide the maximum depth, the areas for swimming, any beaches or steps, seats and hydromassage areas and any possible access free from architectural barricades.

[IT] Modellazione: Decidiamo ora come modellare gli interni senza dimenticare di prevedere gli accessi. Stabiliamo la profondità massima, le zone per il nuoto, eventuali spiagge o gradini, sedute e zone idromassaggio, eventuali accessi privi di barriere architettoniche.

[ES] Modelado: Ahora decidimos cómo modelar el interior. No nos olvidemos de los accesos para entrar o salir de nuestra piscina. Decidir la profundidad máxima, las zonas para nadar, las playas o escalones, los asientos y las zonas de hidromasaje, los accesos sin barreras arquitectónicas.

[FR] Modélisation : Nous décidons maintenant comment modéliser l'intérieur. N'oublions pas les accès pour entrer ou sortir de notre piscine. Décidez de la profondeur maximale, des zones de baignade, des plages ou des marches, des sièges et des zones d'hydromassage, des accès possibles sans barrières architecturales.

[DE] Modellierung: Wir entscheiden jetzt, wie wir den Innenraum gestalten. Vergessen Sie nicht den Zugang zu unserem Pool. Wählen Sie die maximale Tiefe, die Bereiche zum Schwimmen, alle Strände oder Stufen, Sitzgelegenheiten und Whirlpoolbereiche, alle Zugänge ohne architektonische Barrikaden.



BD-01



	20 m ²	30 m ²	40 m ²	50 m ²	60 m ²	70 m ²	80 m ²	90 m ²	100 m ²	110 m ²	120 m ²	
A	4,87m	5,83m	6,64m	7,35m	7,99m	8,58m	9,13m	9,65m	10,14m	10,61m	11,05m	A
B	6,92m	8,35m	9,56m	10,61m	11,55m	12,43m	13,25m	14,02m	14,75m	15,43m	16,09m	B
H	1,20m	1,30m	1,40m	1,40m	1,40m	1,40m	1,40m	1,40m	1,40m	1,40m	1,40m	H

* 30 cm border included | 30 cm di bordo incluso | Borde de 30 cm incluido | Bordure de 30 cm incluse | Inklusive 30 cm Rand

BD-01

| 40 | 50 | 60 |

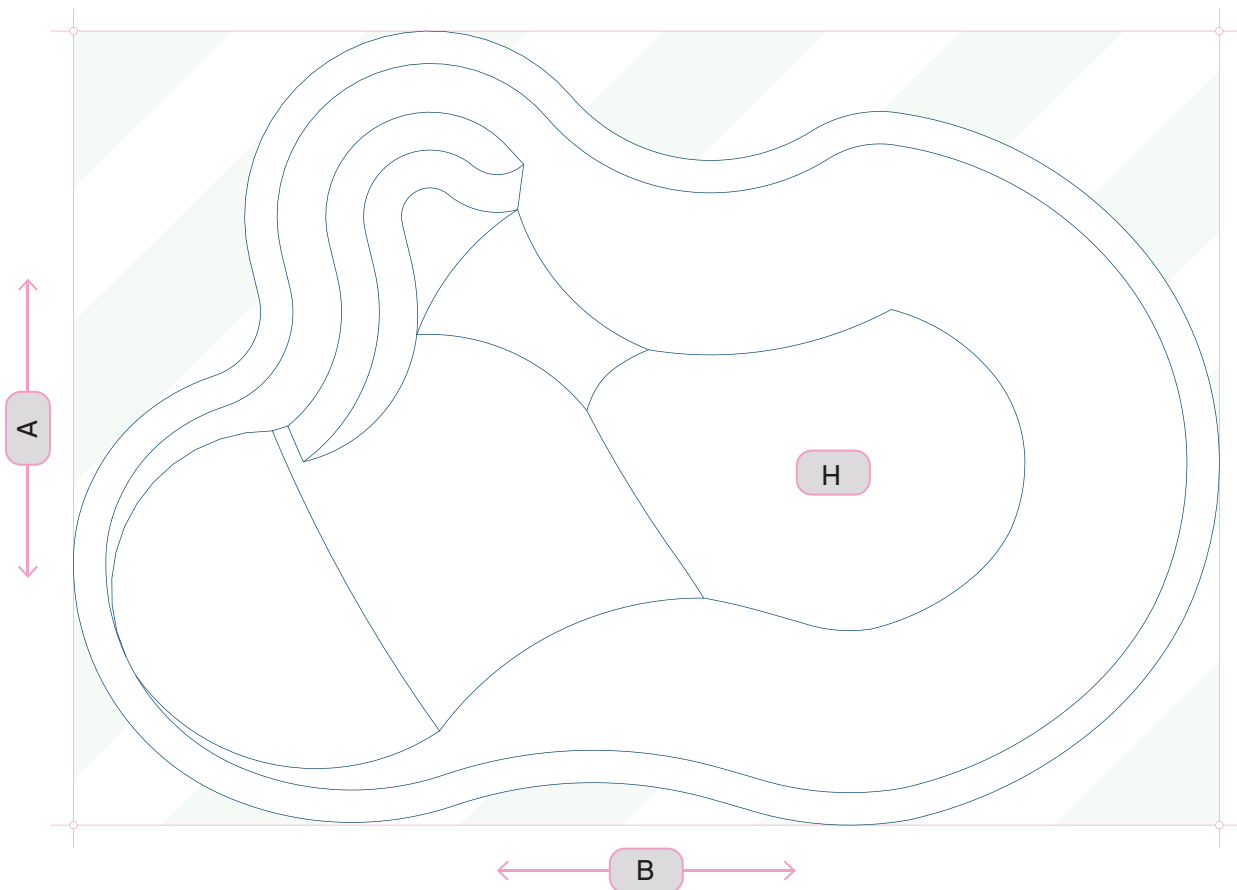

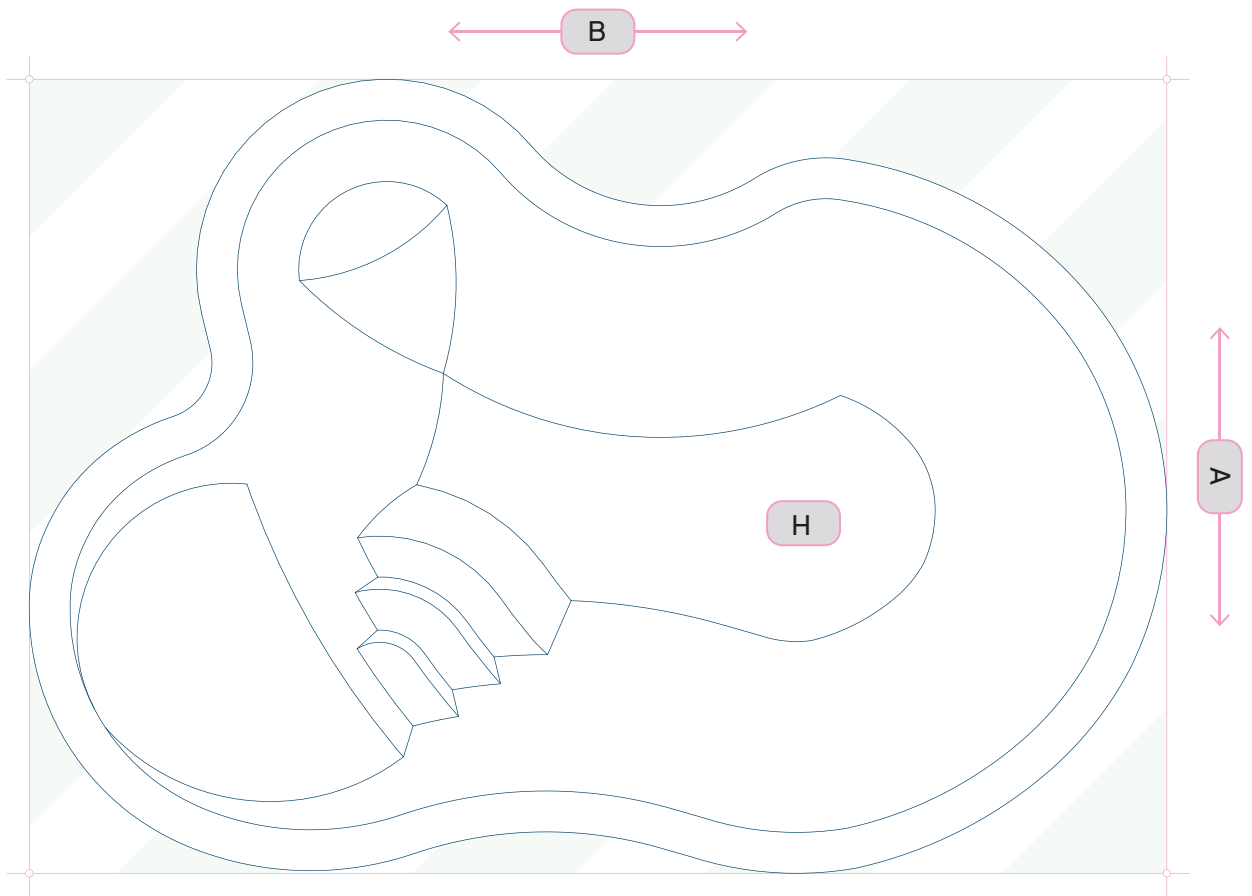

|20|30|

BD-01

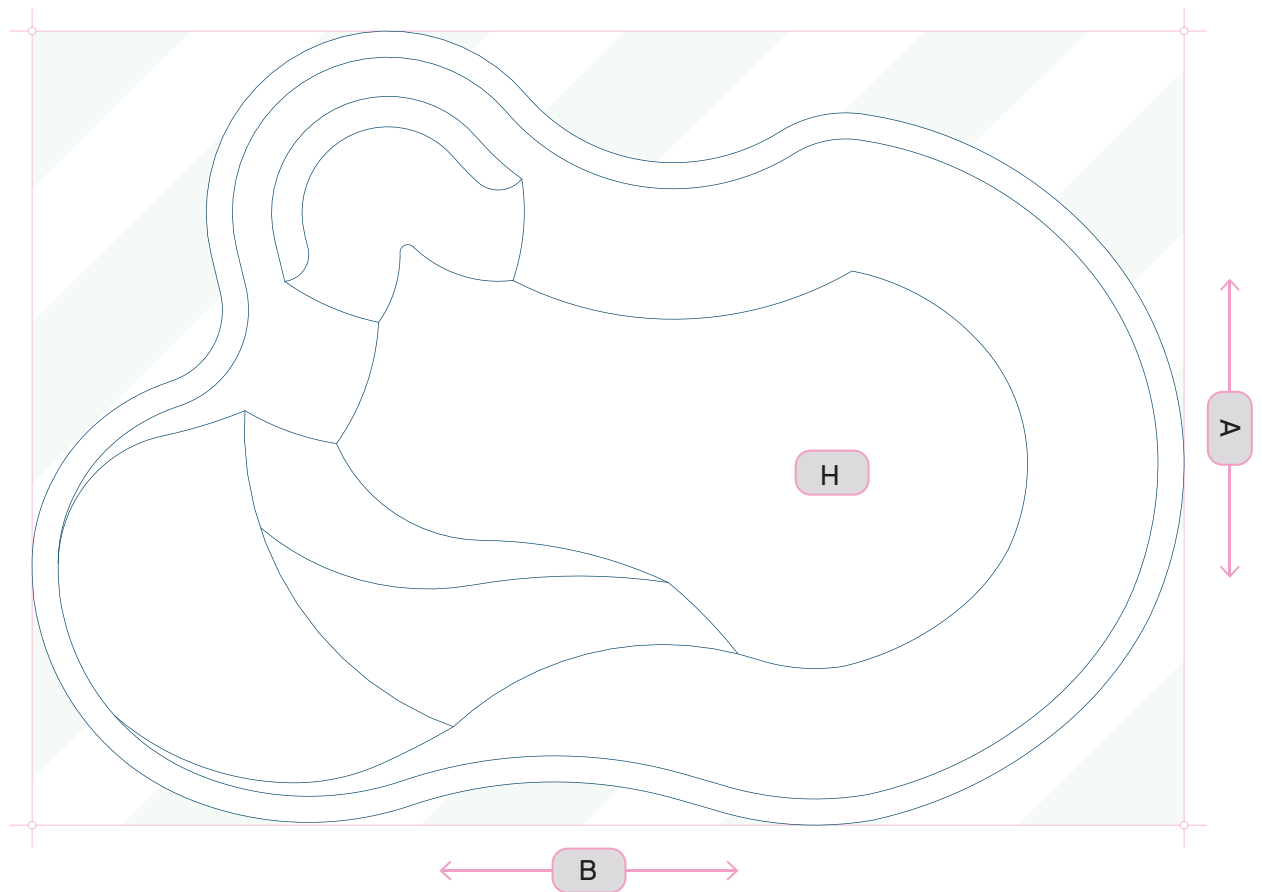

|70|80|90|100|110|120|

BD-01



BD-02

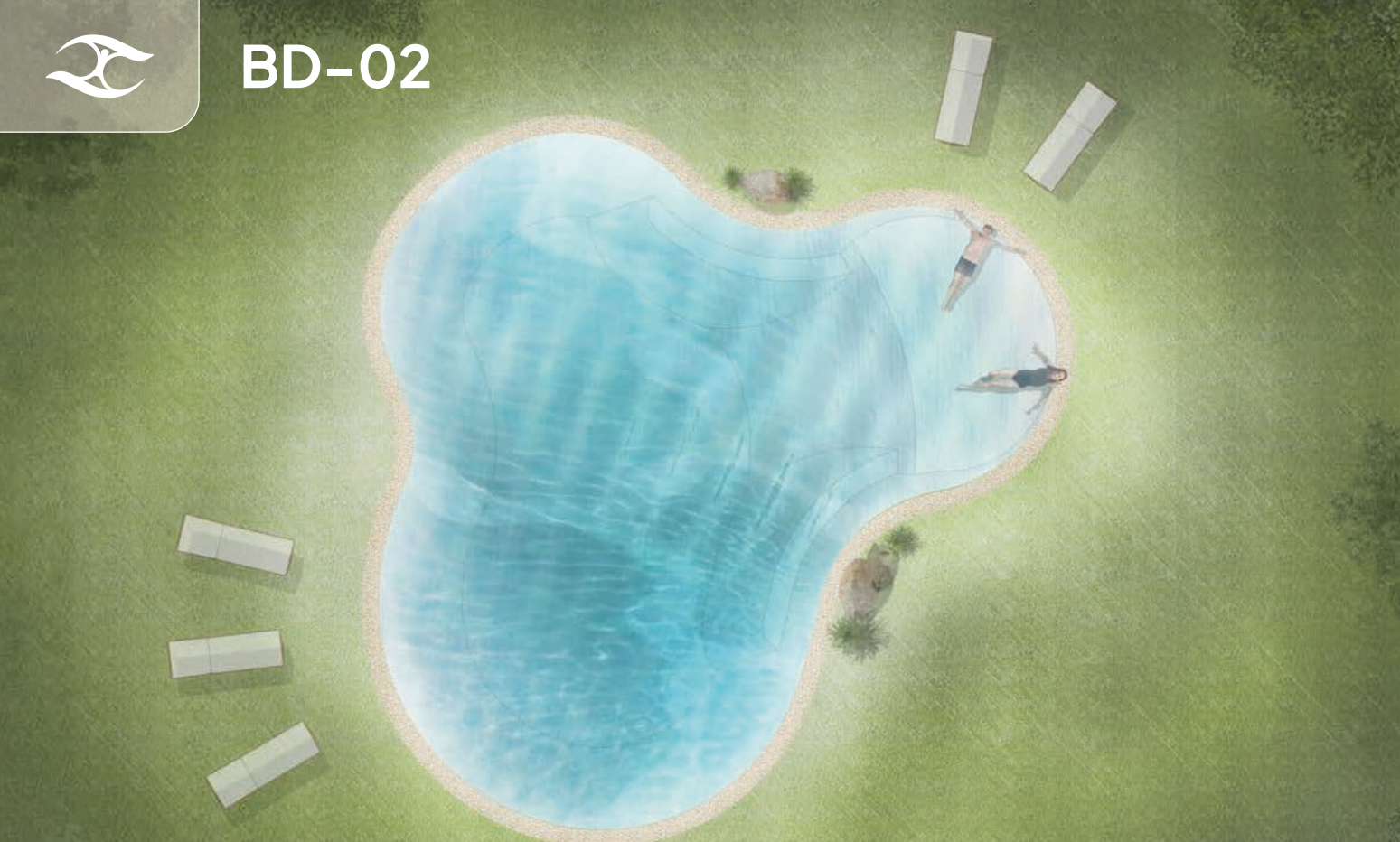

	20 m ²	30 m ²	40 m ²	50 m ²	60 m ²	70 m ²	80 m ²	90 m ²	100 m ²	110 m ²	120 m ²	
A	5,98 m	7,16 m	8,42 m	9,33 m	10,16 m	10,92 m	11,62 m	12,29 m	12,94 m	13,54 m	14,10 m	A
B	5,99 m	7,18 m	8,20 m	9,08 m	9,89 m	10,63 m	11,32 m	11,96 m	12,59 m	13,17 m	13,72 m	B
H	1,20 m	1,30 m	1,40 m	1,40 m	1,40 m	1,40 m	1,40 m	1,40 m	1,40 m	1,40 m	1,40 m	H

* 30 cm border included | 30 cm di bordo incluso | Borde de 30 cm incluido | Bordure de 30 cm incluse | Inklusive 30 cm Rand

BD-02

| 40 | 50 | 60 |

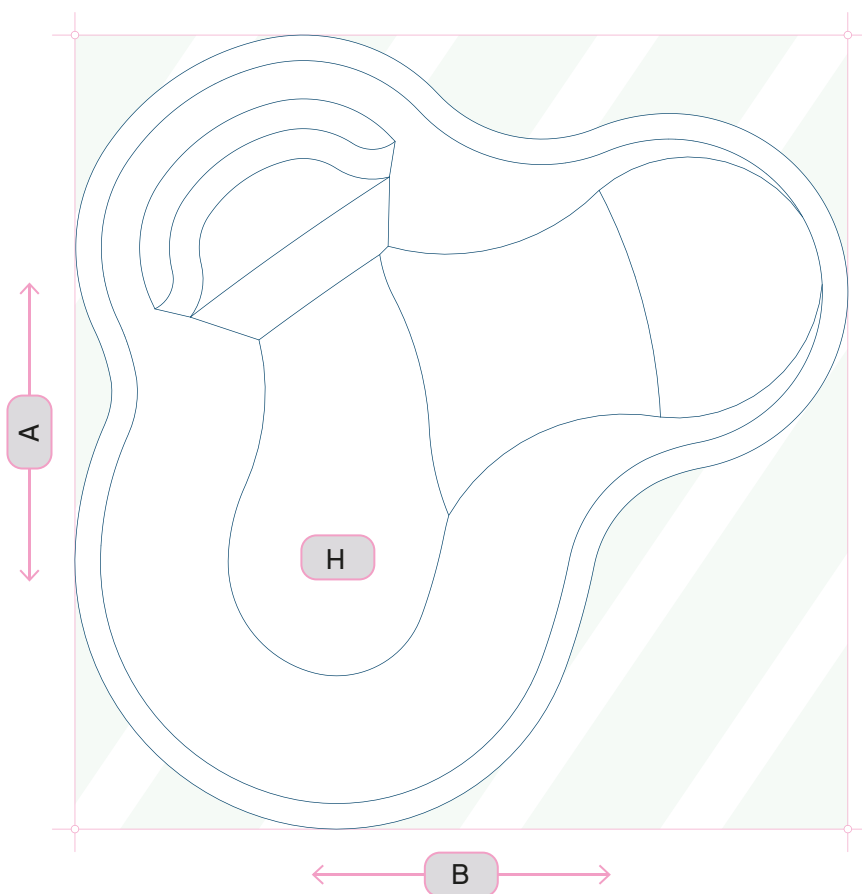

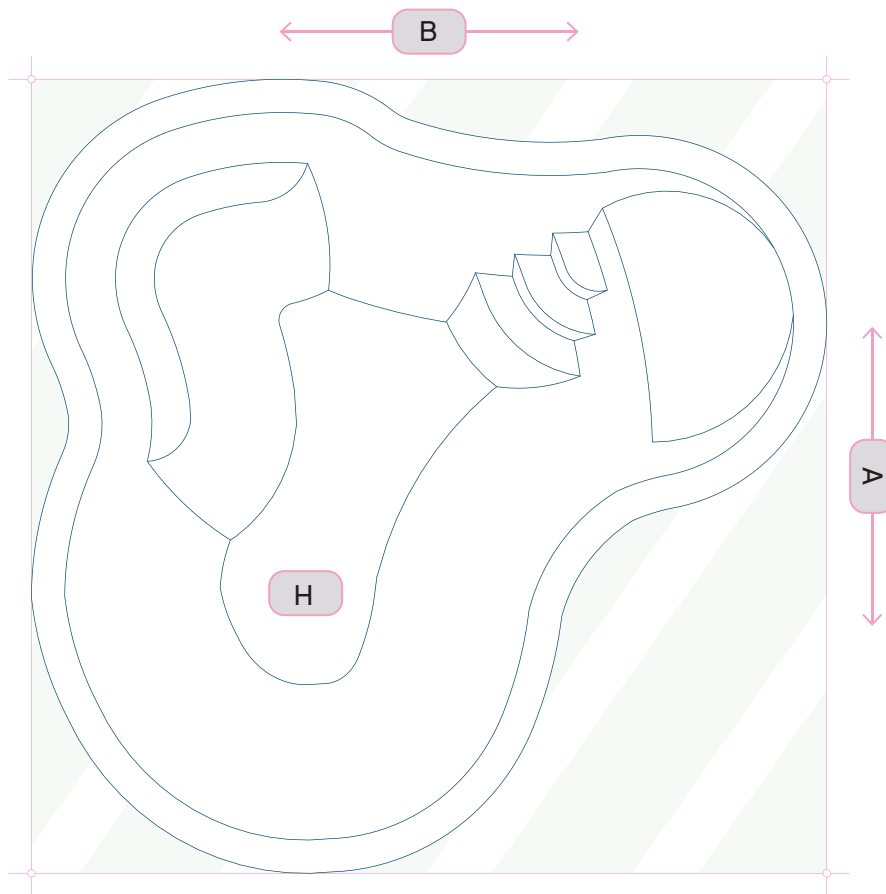

|20|30|

BD-02

|70|80|90|100|110|120|

BD-02

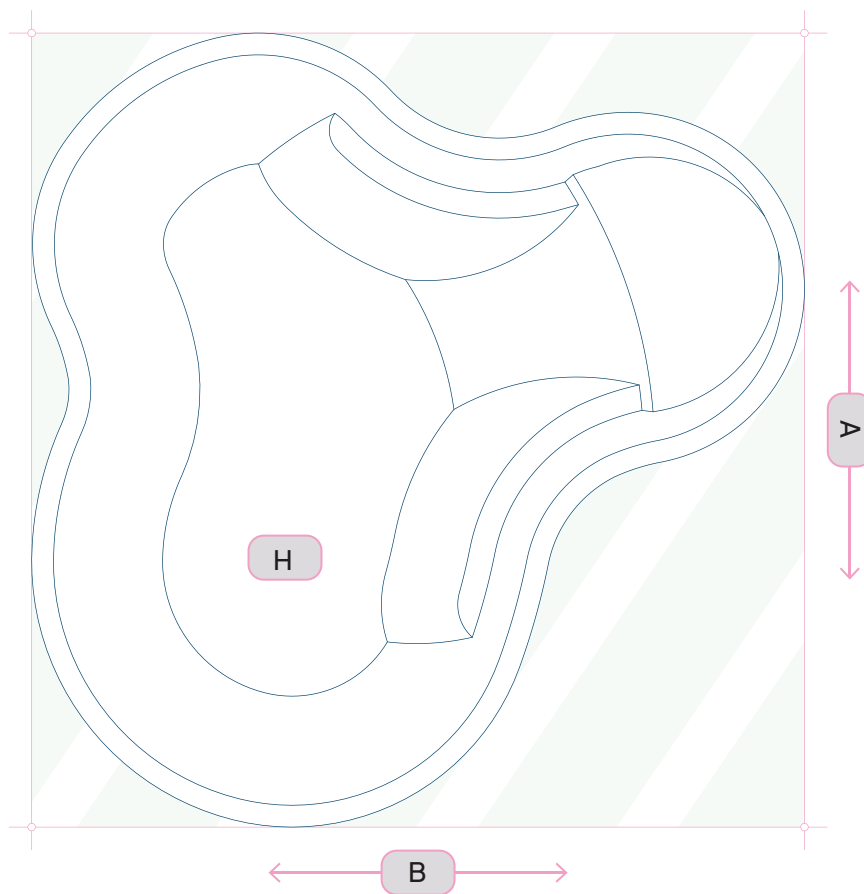



BD-03

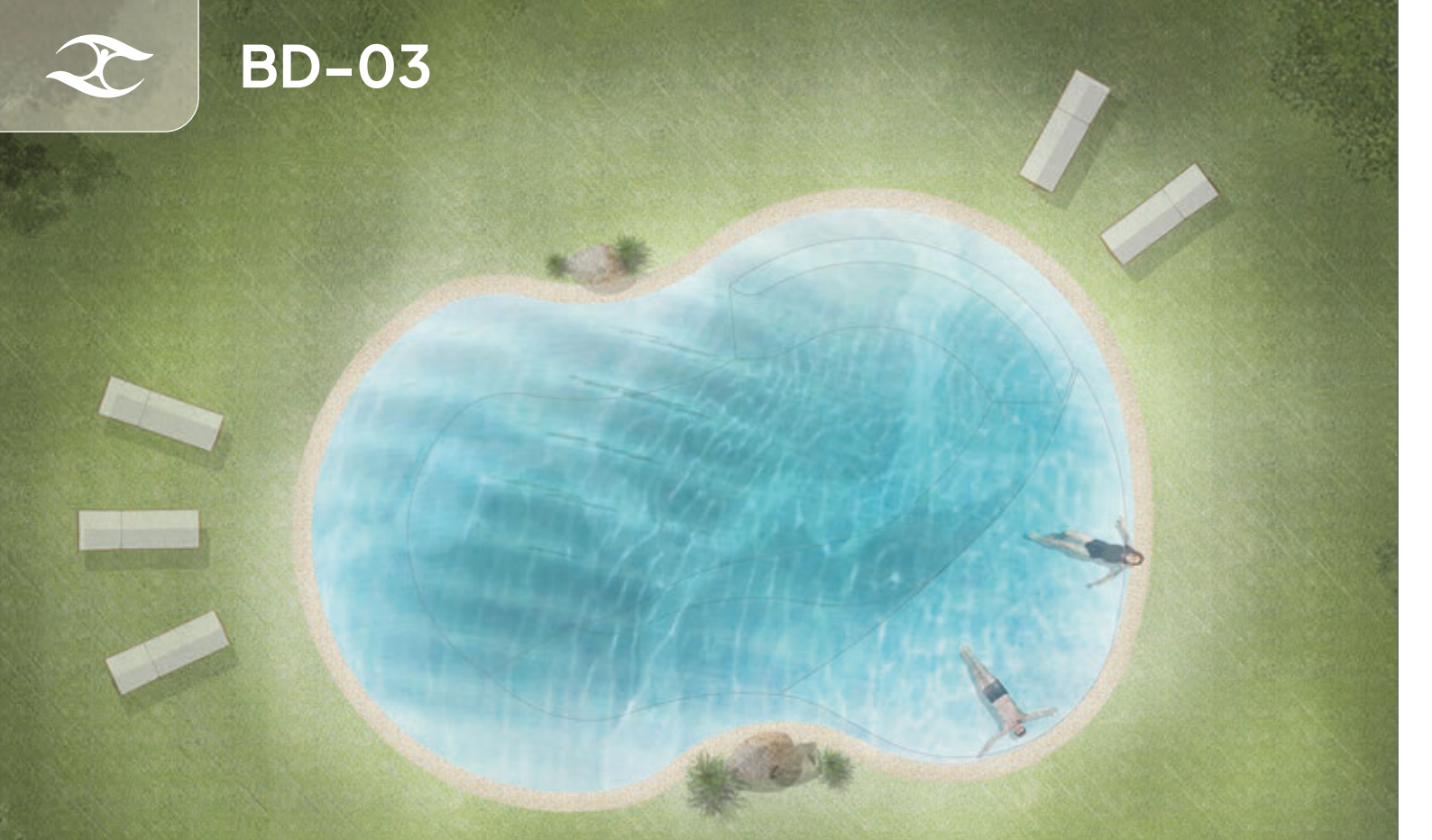

	20 m ²	30 m ²	40 m ²	50 m ²	60 m ²	70 m ²	80 m ²	90 m ²	100 m ²	110 m ²	120 m ²	
A	4,91m	5,87m	6,67m	7,44m	8,09m	8,63m	9,19m	9,7m	10,19m	10,66m	11,10m	A
B	6,65m	8,00m	9,12m	9,97m	10,85m	11,88m	12,67m	13,38m	14,07m	14,73m	15,35m	B
H	1,20m	1,30m	1,40m	1,40m	1,40m	1,40m	1,40m	1,40m	1,40m	1,40m	1,40m	H

* 30 cm border included | 30 cm di bordo incluso | Borde de 30 cm incluido | Bordure de 30 cm incluse | Inklusive 30 cm Rand

BD-03

|40|50|60|

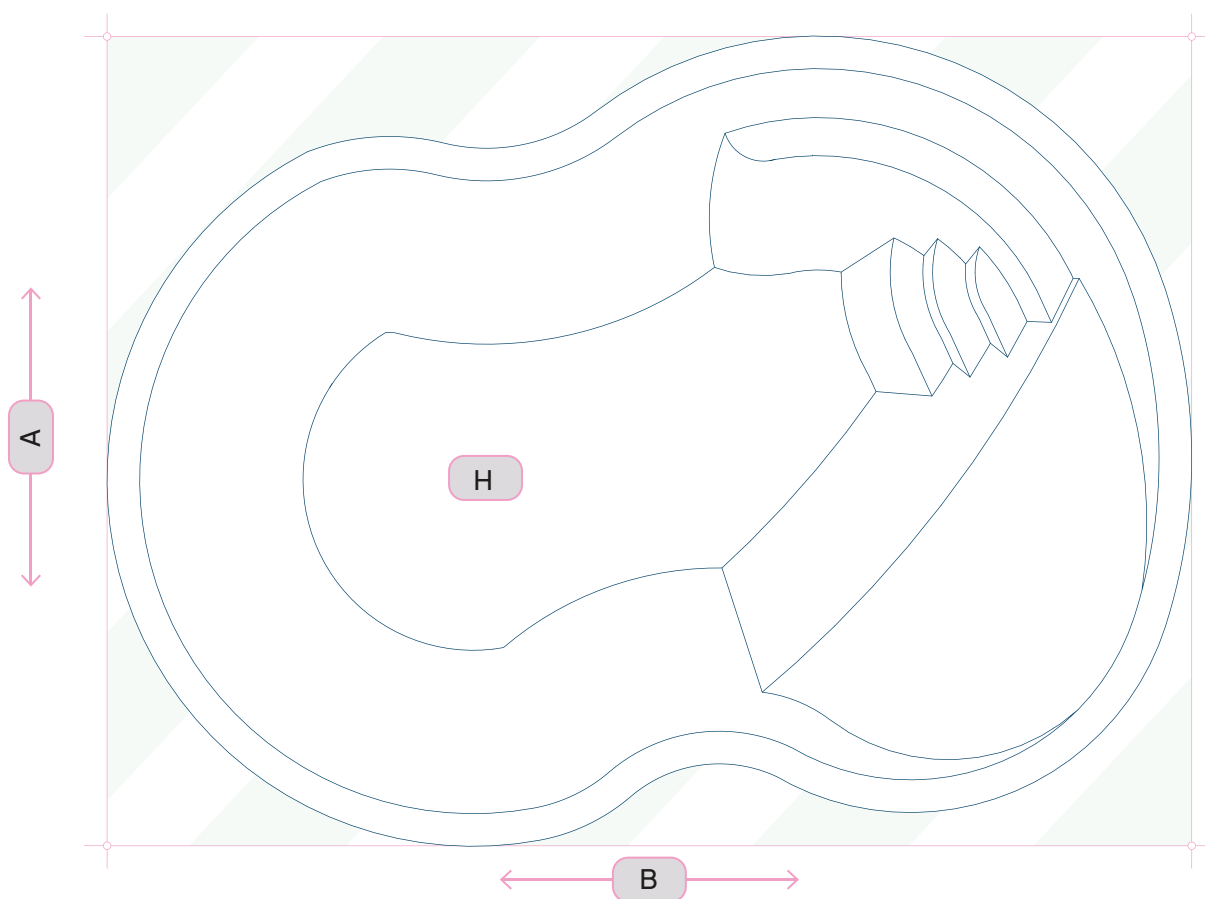

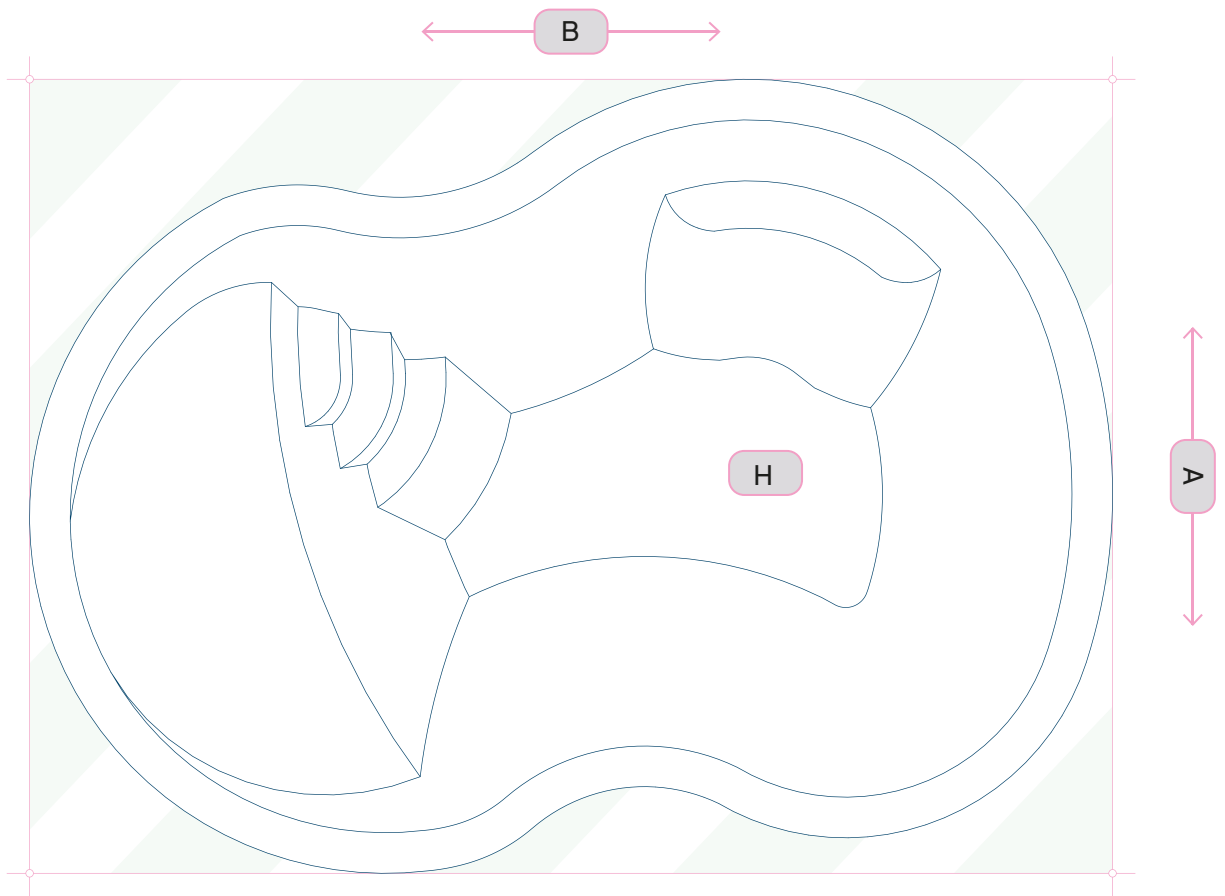

|20|30|

BD-03

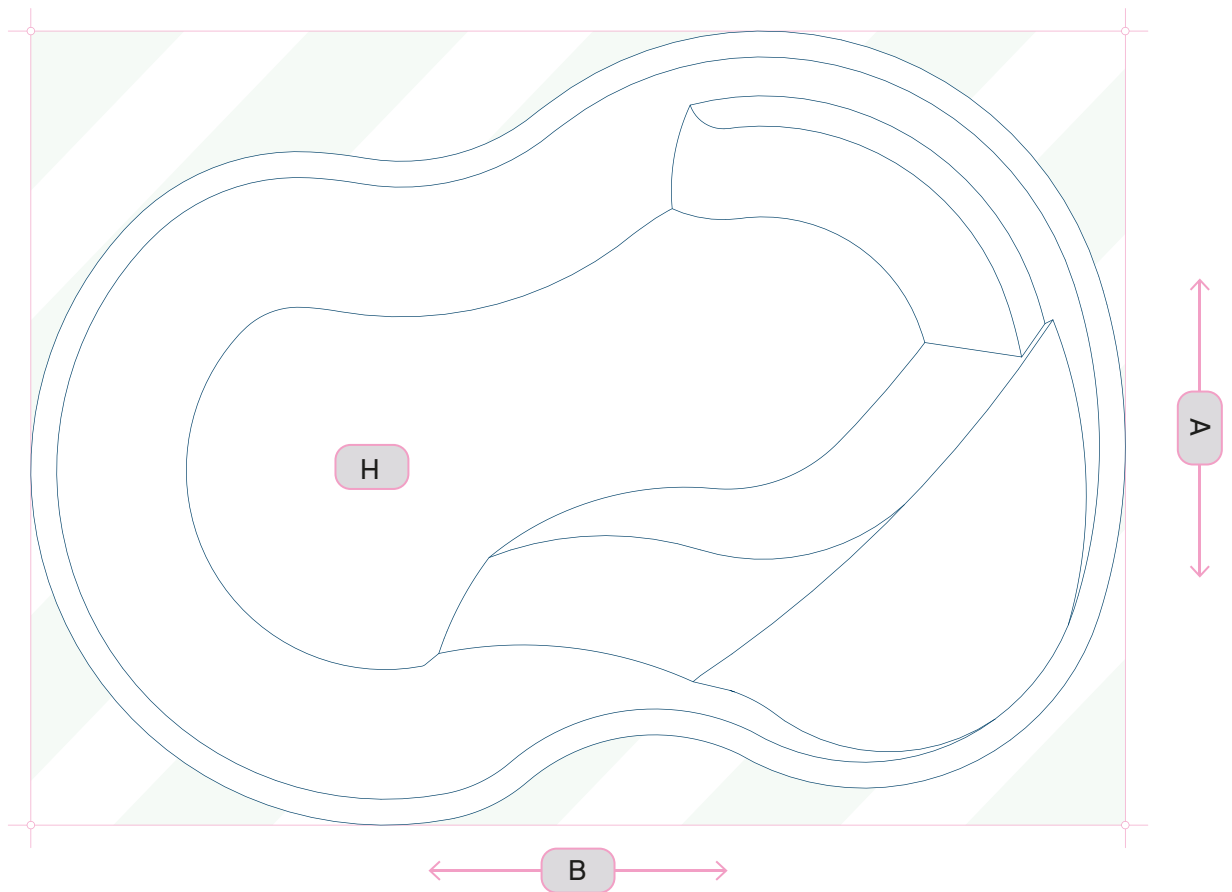

|70|80|90|100|110|120|

BD-03



BD-04

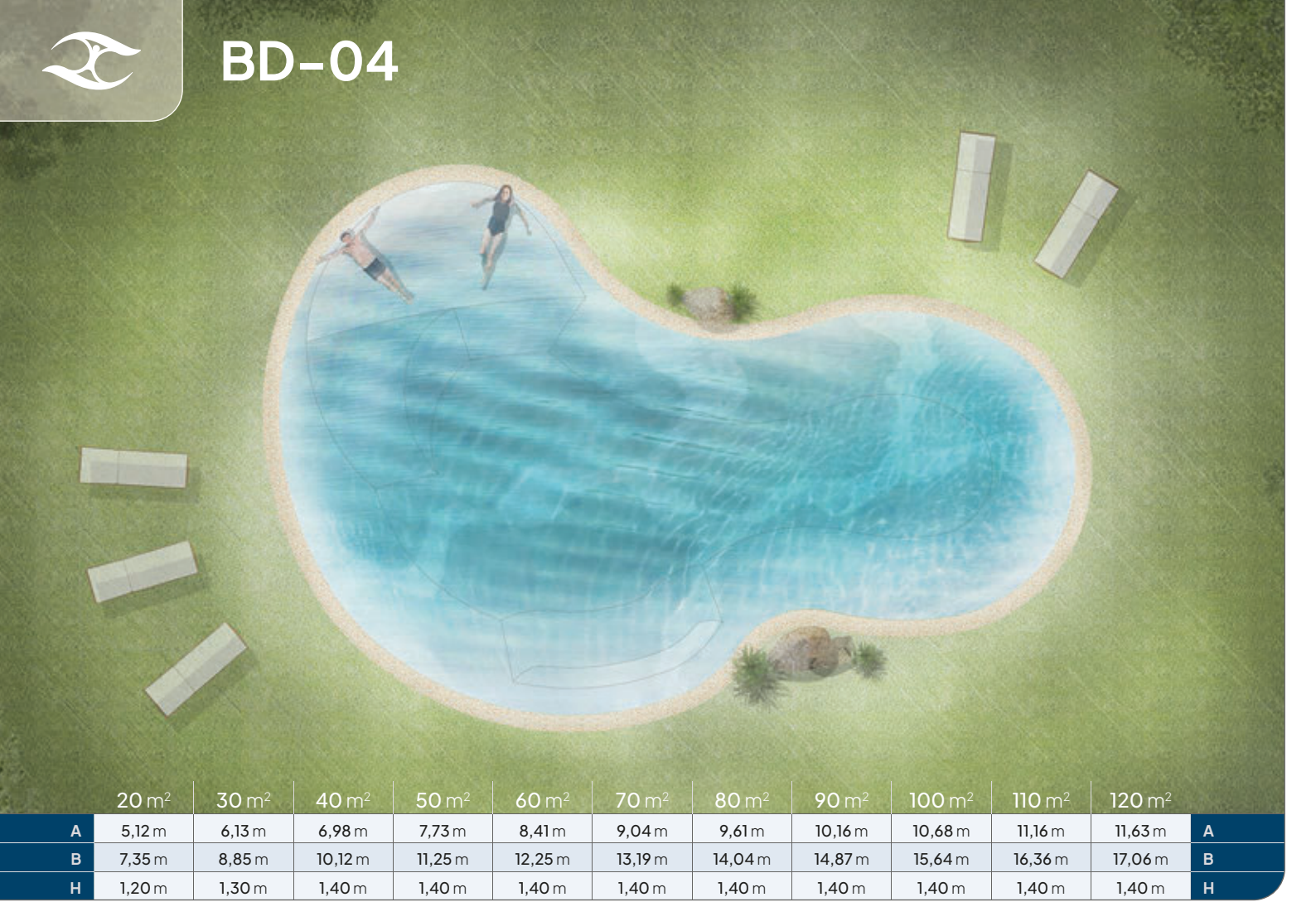

	20 m ²	30 m ²	40 m ²	50 m ²	60 m ²	70 m ²	80 m ²	90 m ²	100 m ²	110 m ²	120 m ²	
A	5,12 m	6,13 m	6,98 m	7,73 m	8,41 m	9,04 m	9,61 m	10,16 m	10,68 m	11,16 m	11,63 m	A
B	7,35 m	8,85 m	10,12 m	11,25 m	12,25 m	13,19 m	14,04 m	14,87 m	15,64 m	16,36 m	17,06 m	B
H	1,20 m	1,30 m	1,40 m	1,40 m	1,40 m	1,40 m	1,40 m	1,40 m	1,40 m	1,40 m	1,40 m	H

* 30 cm border included | 30 cm di bordo incluso | Borde de 30 cm incluido | Bordure de 30 cm incluse | Inklusive 30 cm Rand

BD-04

| 50 | 60 | 70 | 80 |

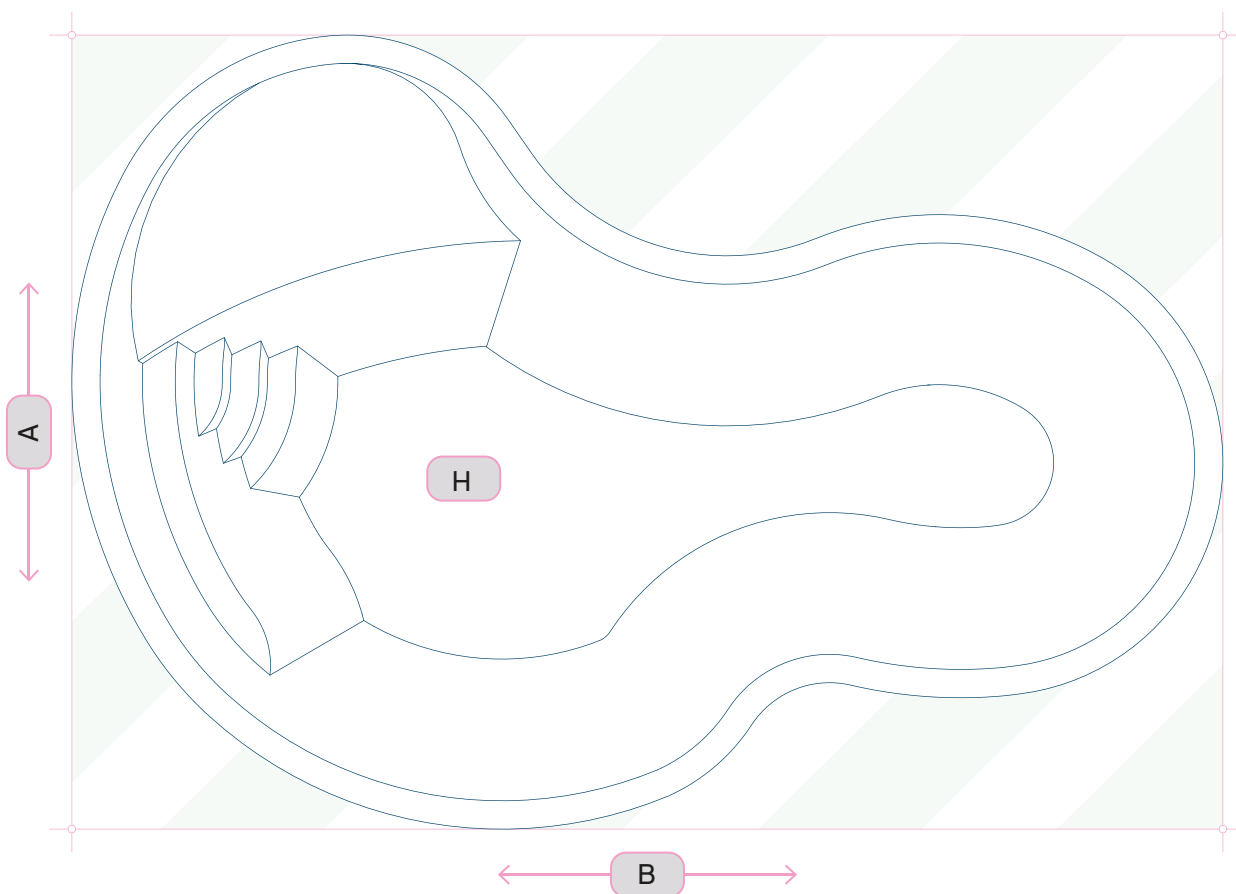

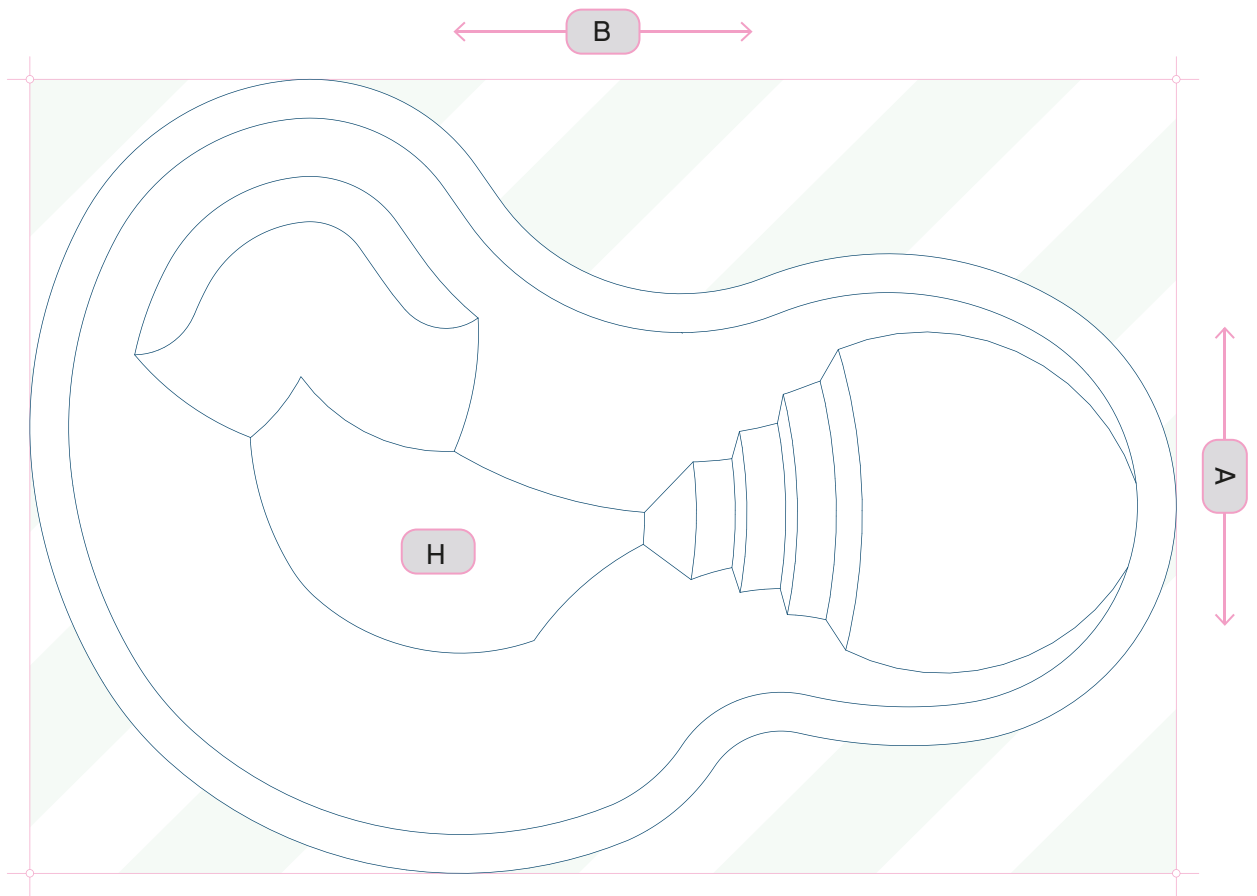

|20|30|40|

BD-04

|80|90|100|110|120|

BD-04

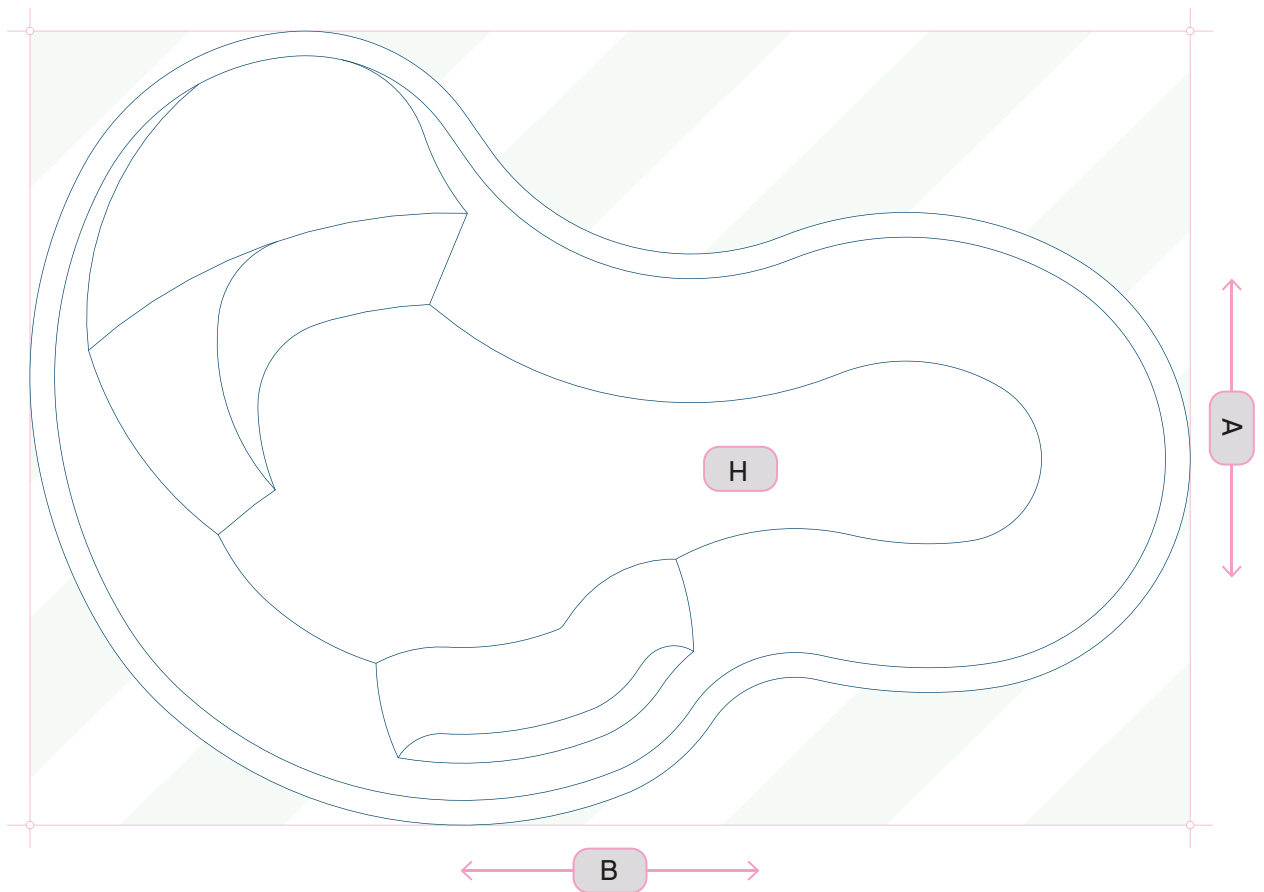



BD-05

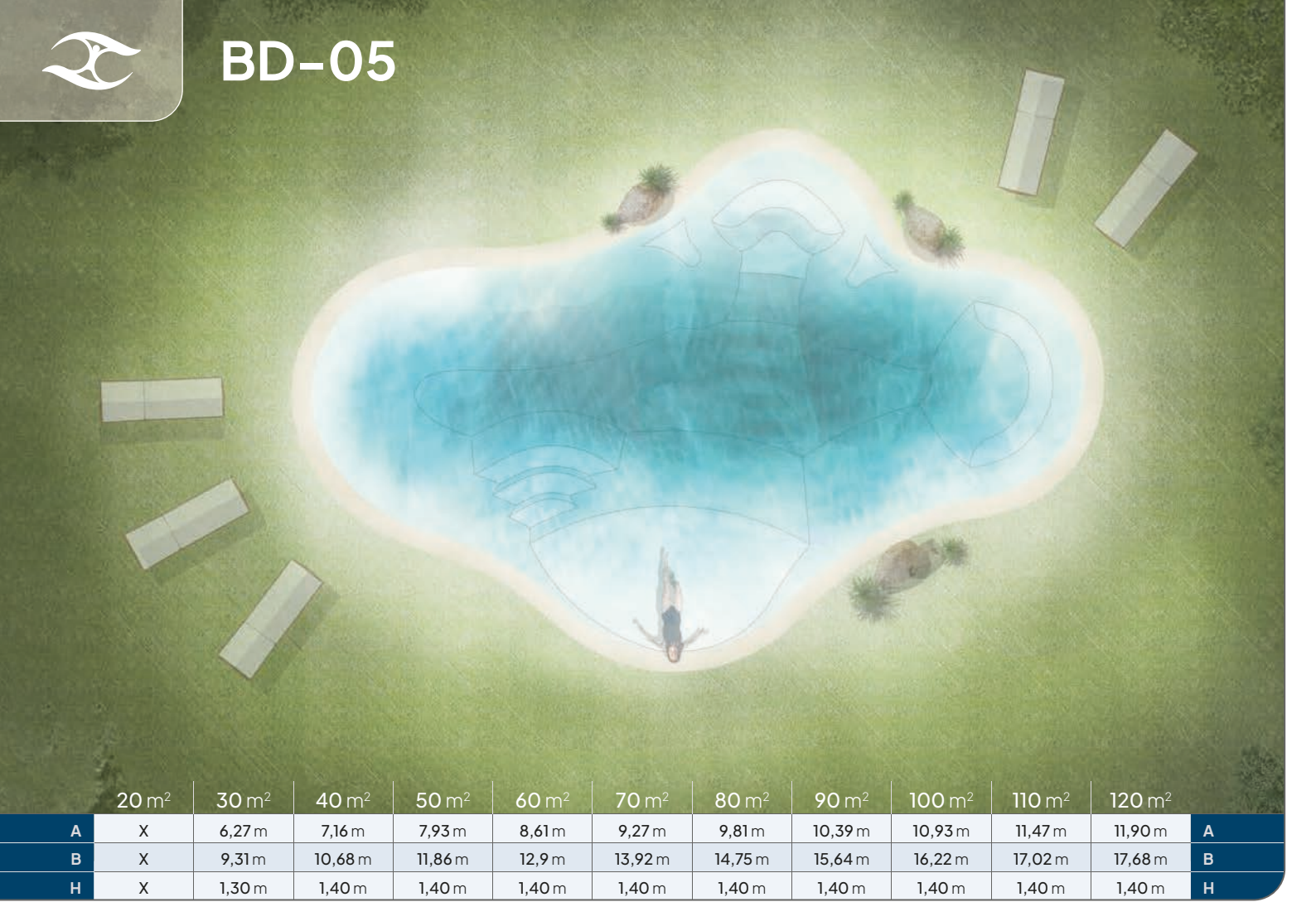

	20 m ²	30 m ²	40 m ²	50 m ²	60 m ²	70 m ²	80 m ²	90 m ²	100 m ²	110 m ²	120 m ²	
A	X	6,27 m	7,16 m	7,93 m	8,61 m	9,27 m	9,81 m	10,39 m	10,93 m	11,47 m	11,90 m	A
B	X	9,31 m	10,68 m	11,86 m	12,9 m	13,92 m	14,75 m	15,64 m	16,22 m	17,02 m	17,68 m	B
H	X	1,30 m	1,40 m	1,40 m	1,40 m	1,40 m	1,40 m	1,40 m	1,40 m	1,40 m	1,40 m	H

* 30 cm border included | 30 cm di bordo incluso | Borde de 30 cm incluido | Bordure de 30 cm incluse | Inklusive 30 cm Rand

BD-05

| 40 | 50 | 60 | 70 | 80 | 90 |

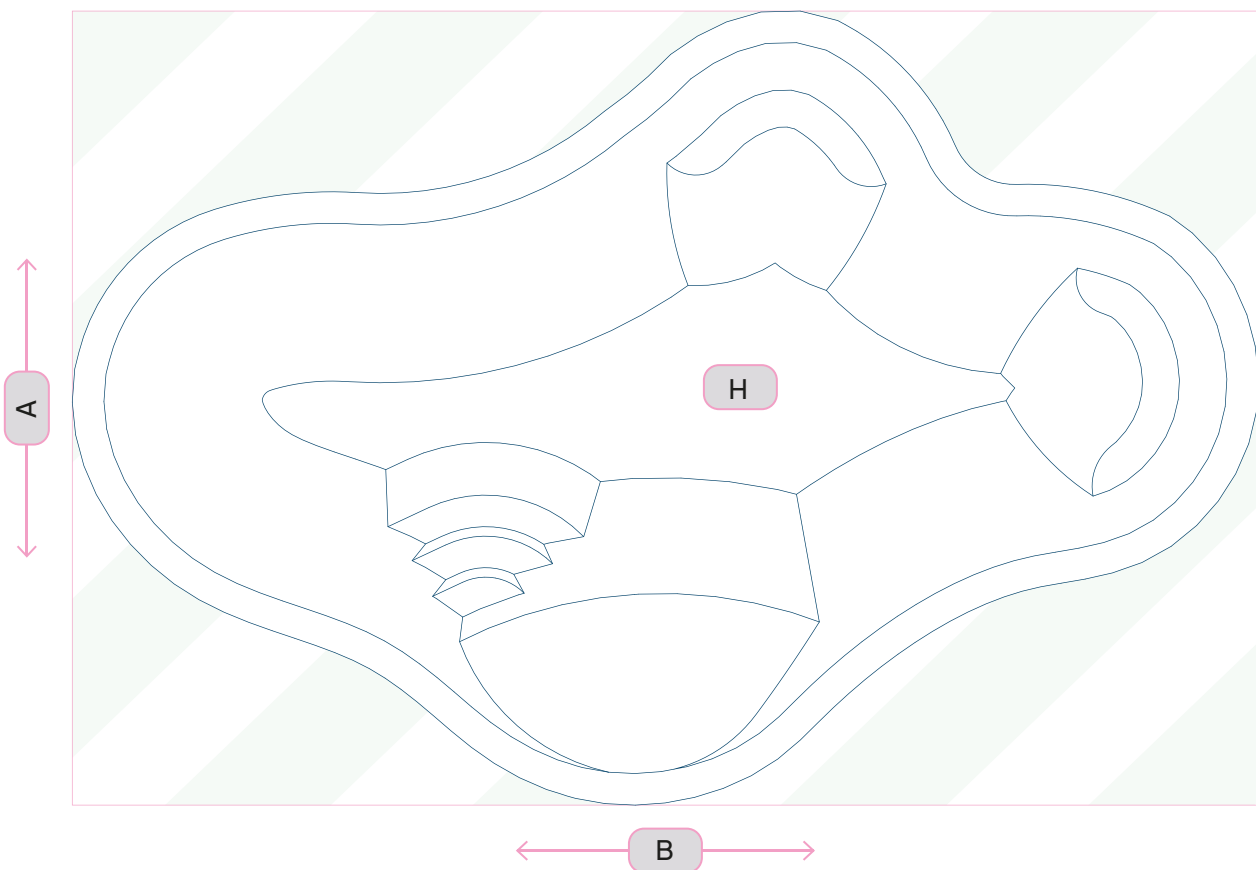

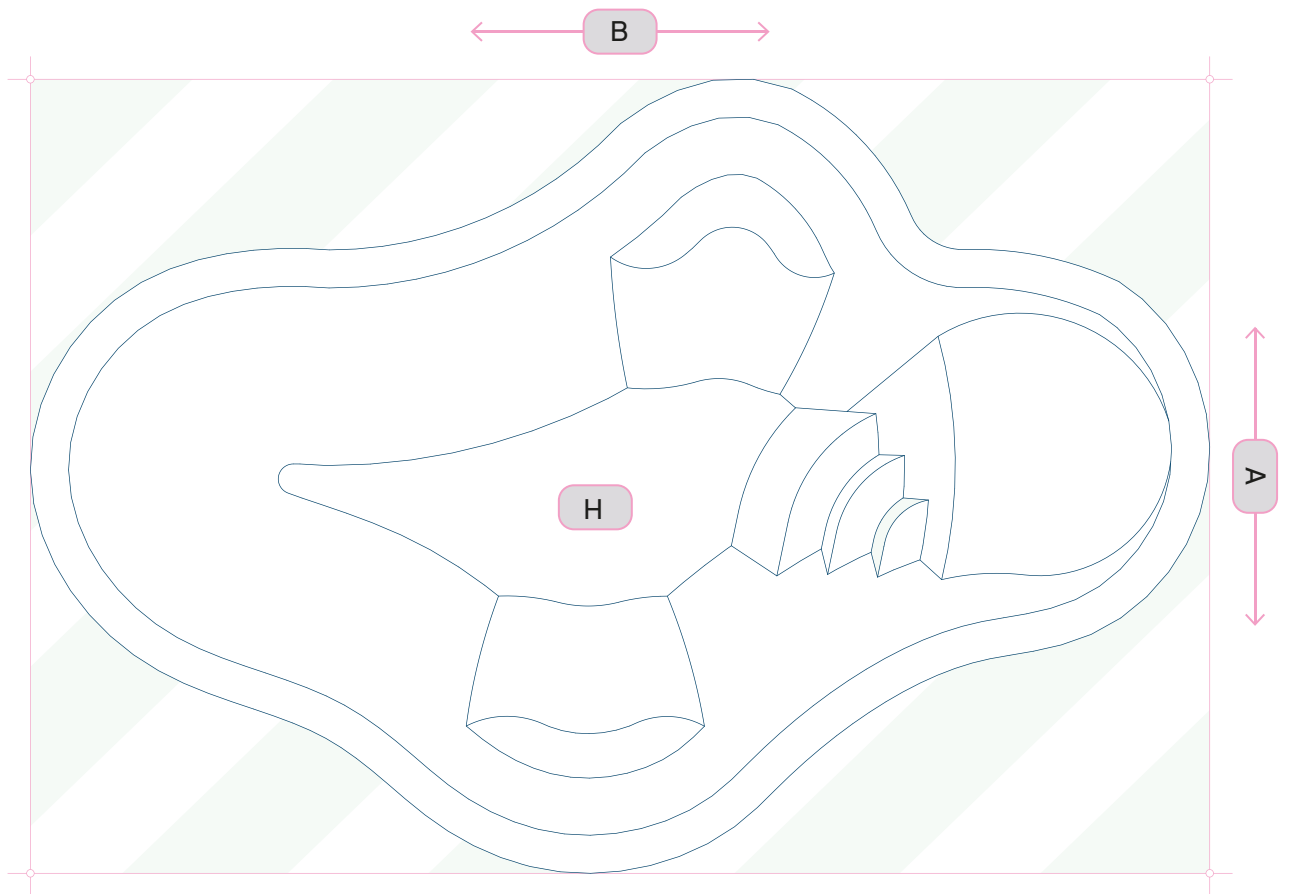

| 30 |

BD-05

| 100 | 110 | 120 |

BD-05

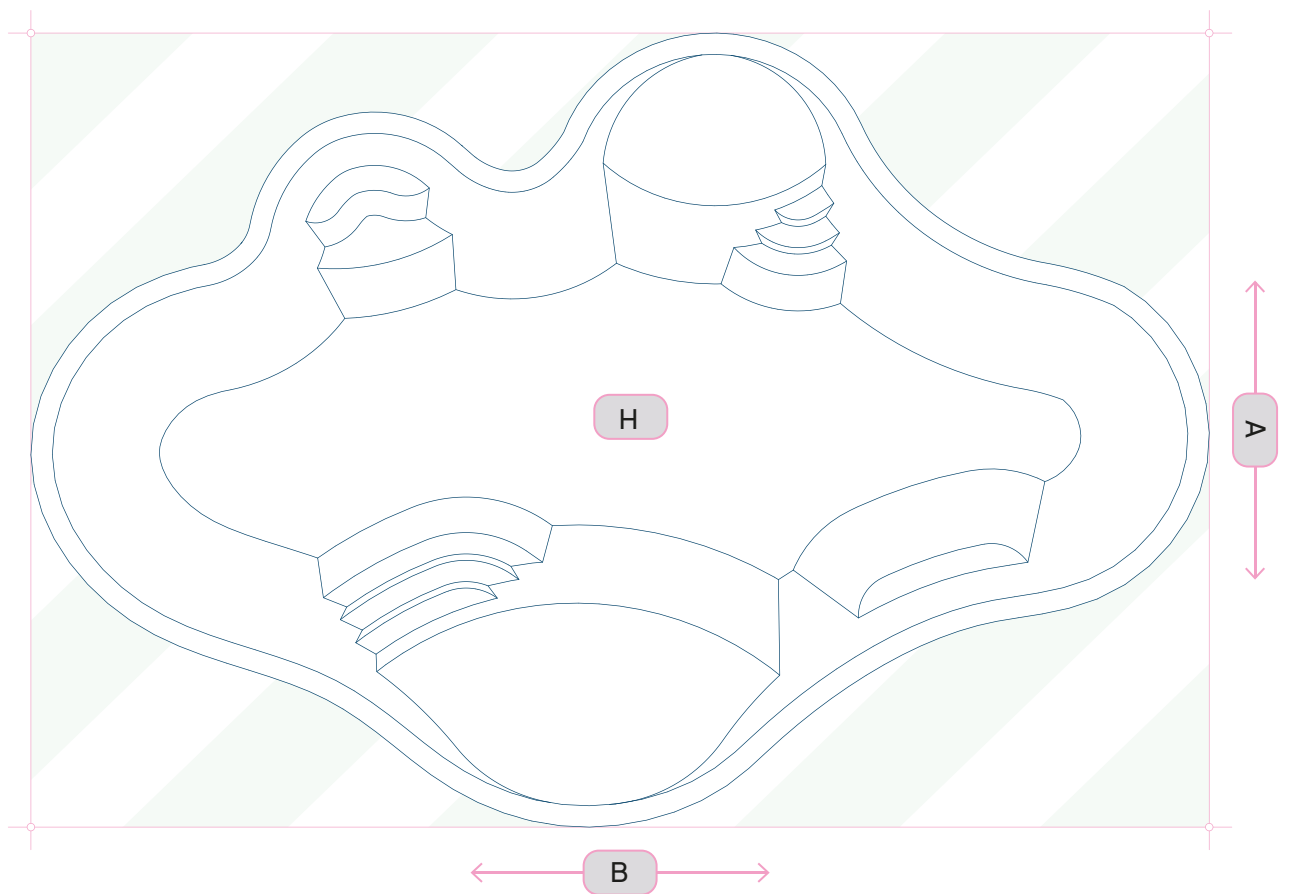



BD-06

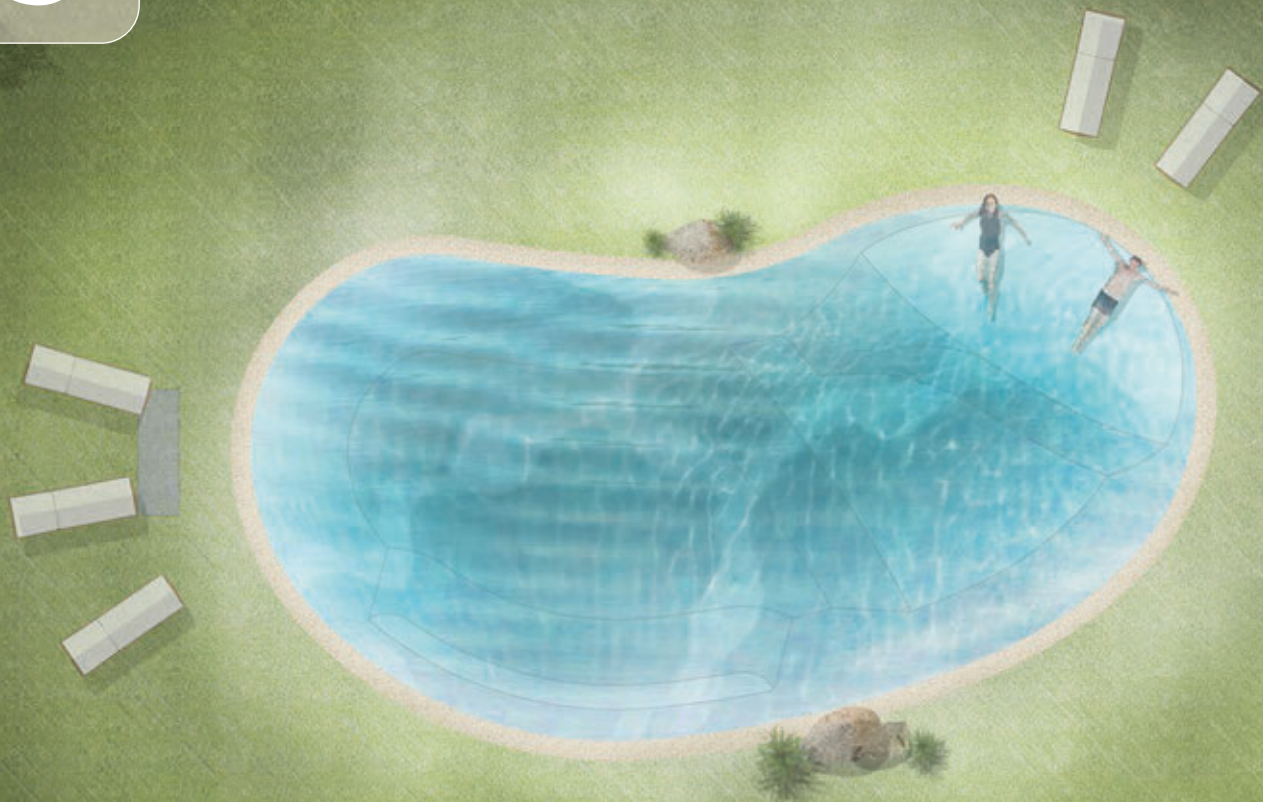

	20 m ²	30 m ²	40 m ²	50 m ²	60 m ²	70 m ²	80 m ²	90 m ²	100 m ²	110 m ²	120 m ²	
A	4,47 m	5,34 m	6,06 m	6,71 m	7,29 m	7,83 m	8,33 m	8,80 m	9,24 m	9,66 m	10,06 m	A
B	7,43 m	8,96 m	10,24 m	11,39 m	12,41 m	13,36 m	14,24 m	15,06 m	15,84 m	16,58 m	17,29 m	B
H	1,20 m	1,30 m	1,40 m	1,40 m	1,40 m	1,40 m	1,40 m	1,40 m	1,40 m	1,40 m	1,40 m	H

* 30 cm border included | 30 cm di bordo incluso | Borde de 30 cm incluido | Bordure de 30 cm incluse | Inklusive 30 cm Rand

BD-06

| 40 | 50 | 60 |

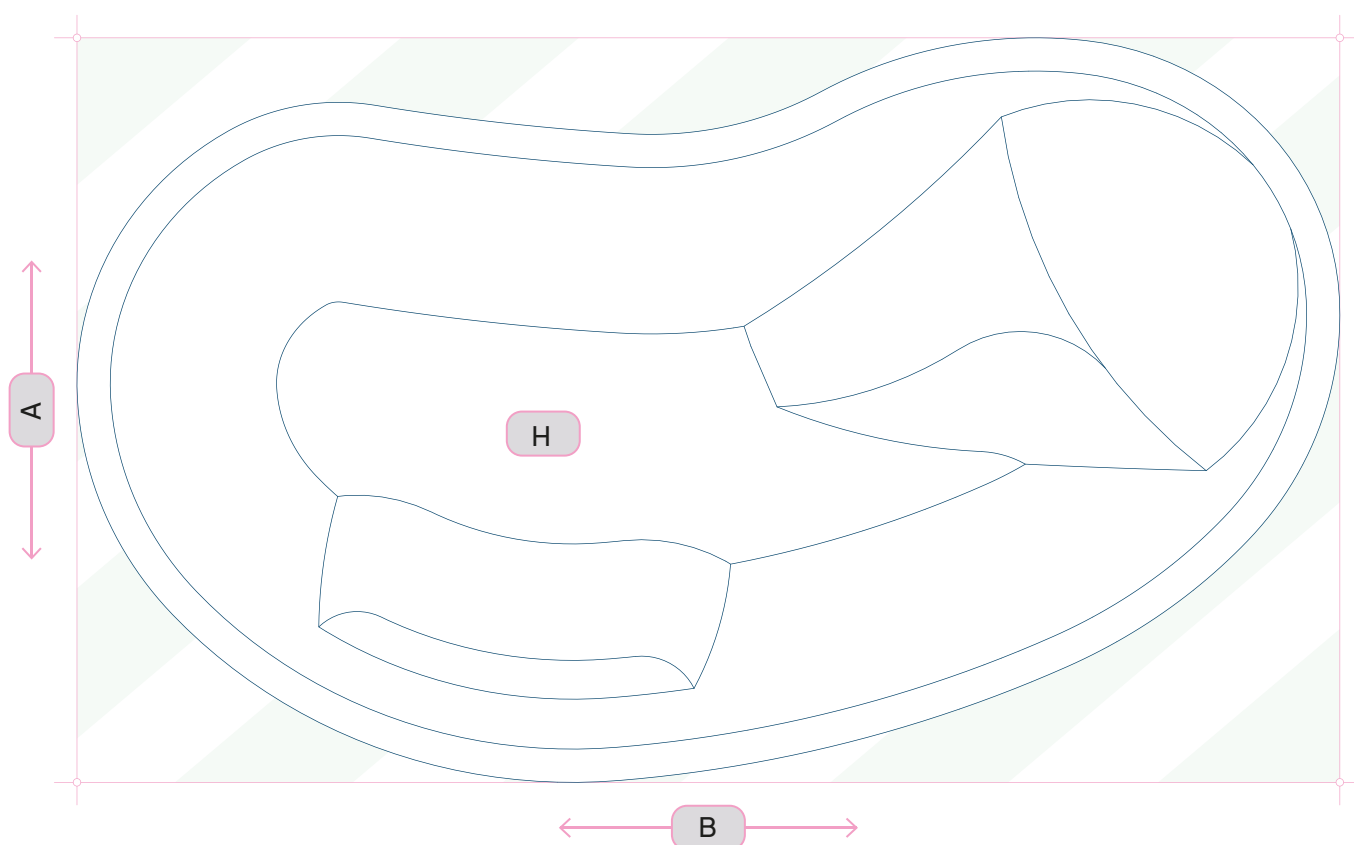

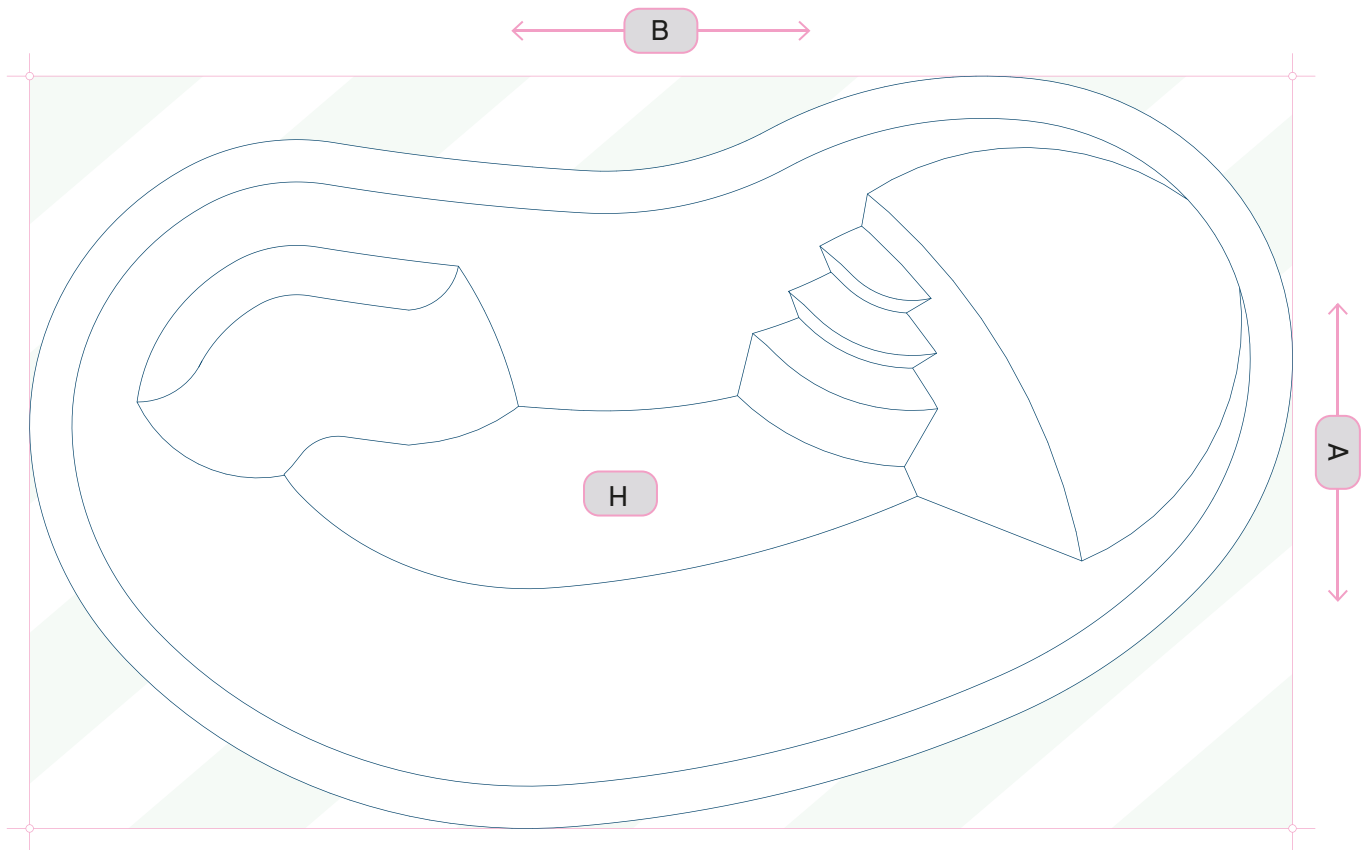

|20|30|

BD-06

|70|80|90|100|110|120|

BD-06

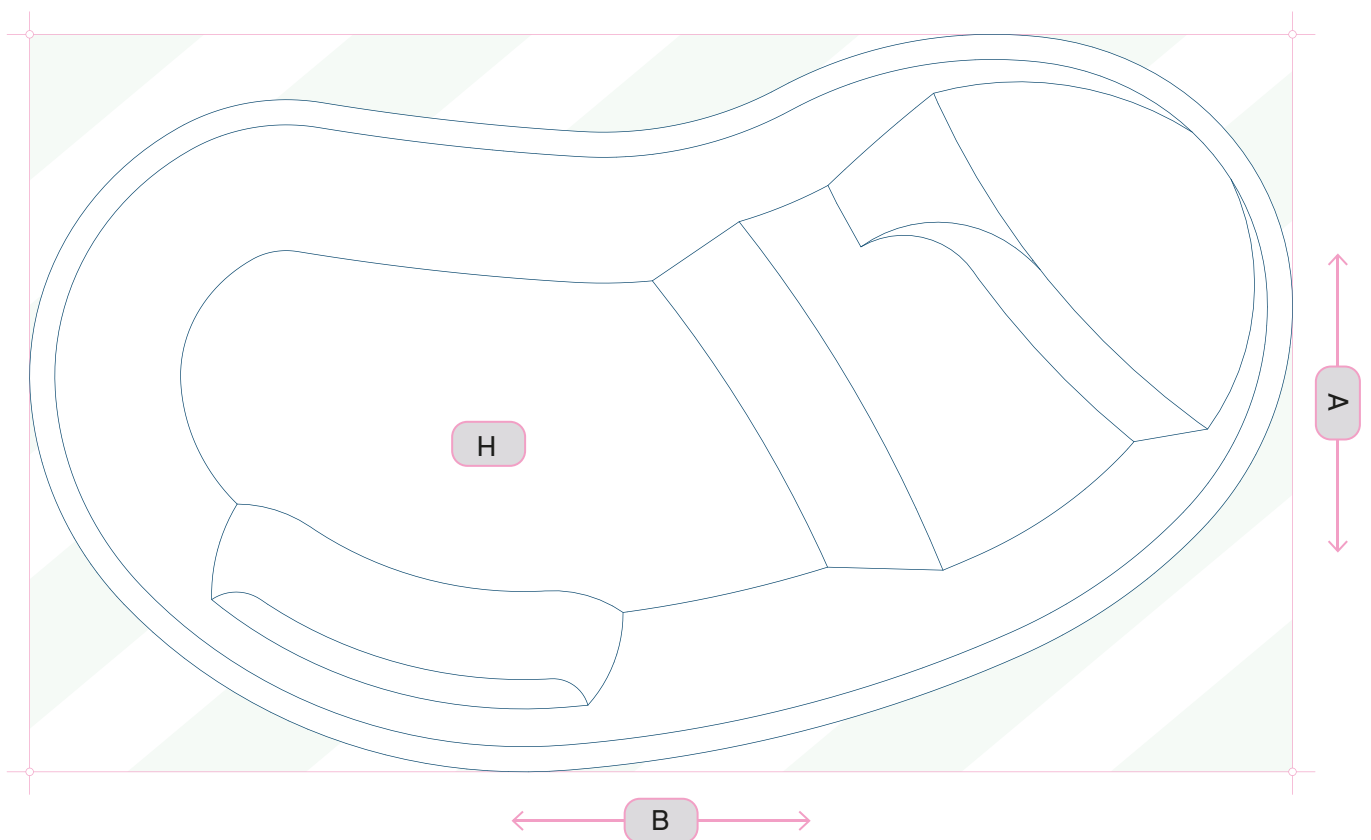



BD-07

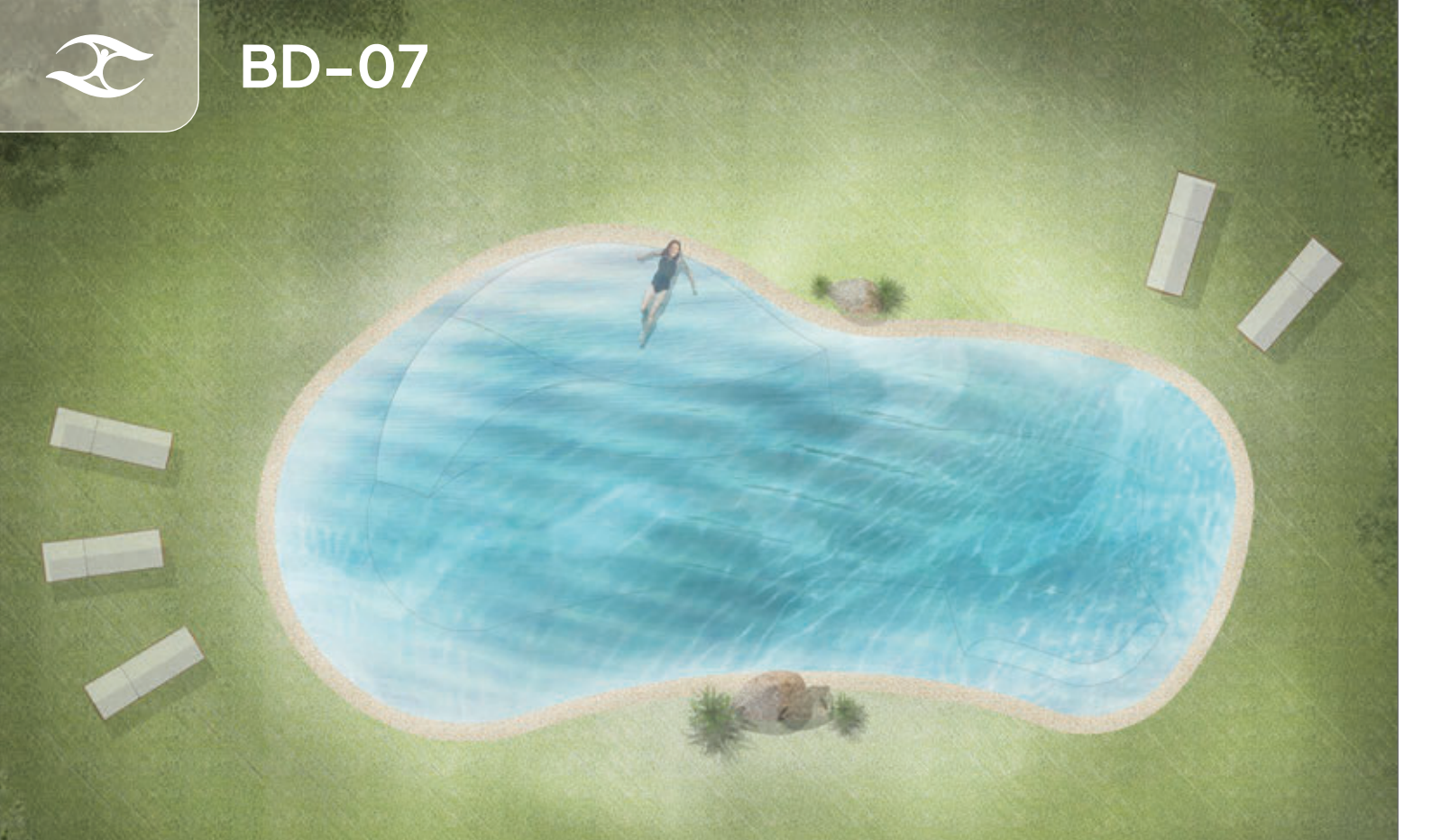

	20 m ²	30 m ²	40 m ²	50 m ²	60 m ²	70 m ²	80 m ²	90 m ²	100 m ²	110 m ²	120 m ²	
A	X	5,09	5,78 m	6,40 m	6,94 m	7,45 m	7,92 m	8,36 m	8,79 m	9,19 m	9,57 m	A
B	X	9,59	10,97 m	12,21 m	13,3 m	14,31 m	15,27 m	16,15 m	17,00 m	17,8 m	18,56 m	B
H	X	1,30 m	1,40 m	1,40 m	1,40 m	1,40 m	1,40 m	1,40 m	1,40 m	1,40 m	1,40 m	H

* 30 cm border included | 30 cm di bordo incluso | Borde de 30 cm incluido | Bordure de 30 cm incluse | Inklusive 30 cm Rand

BD-07

| 40 | 50 | 60 |

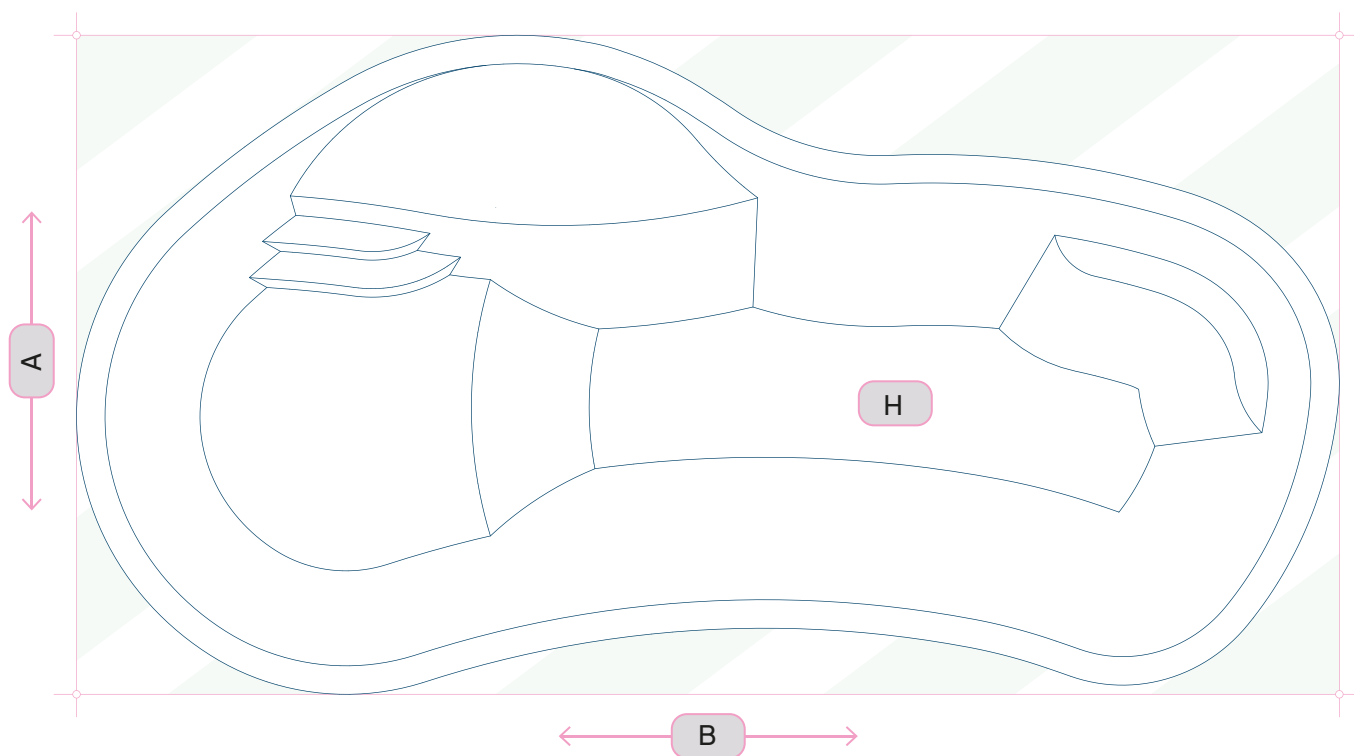

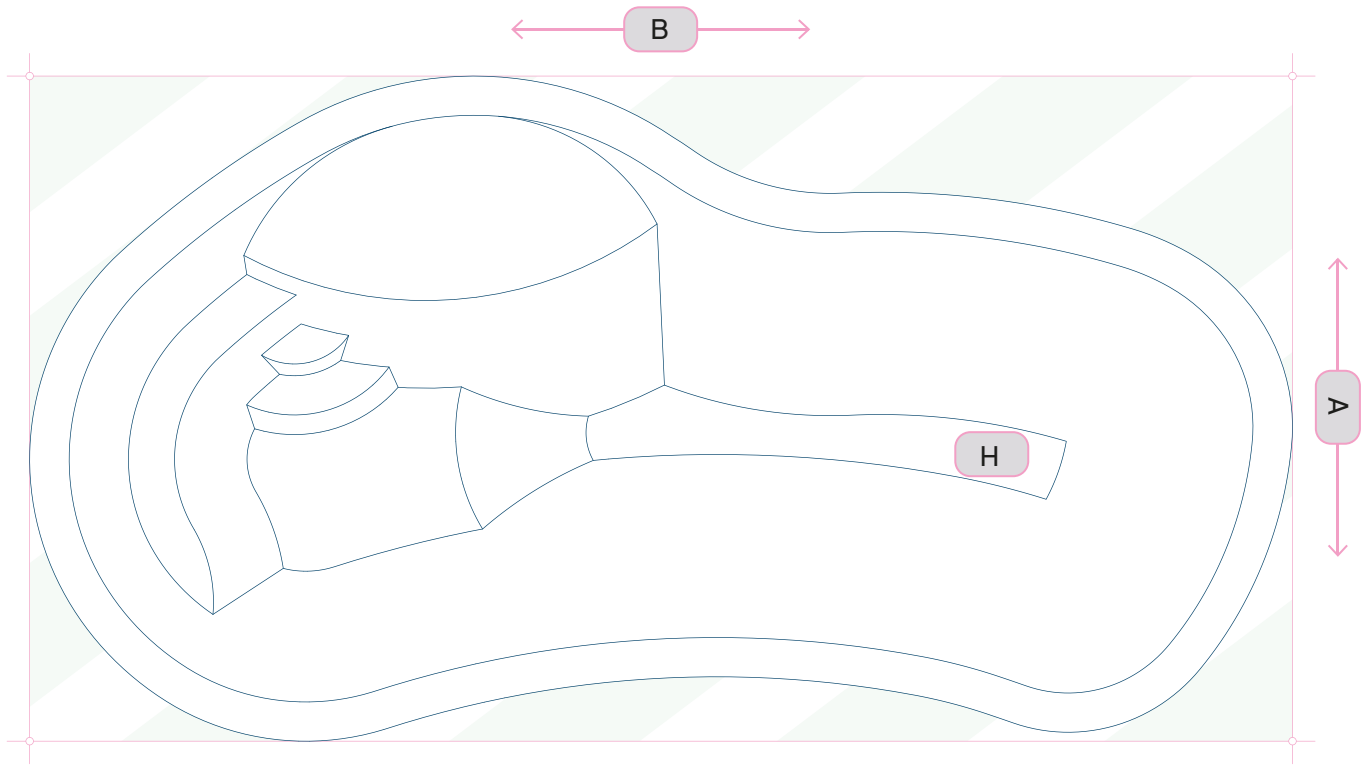

| 30 |

BD-07

| 70 | 80 | 90 | 100 | 110 | 120 |

BD-07

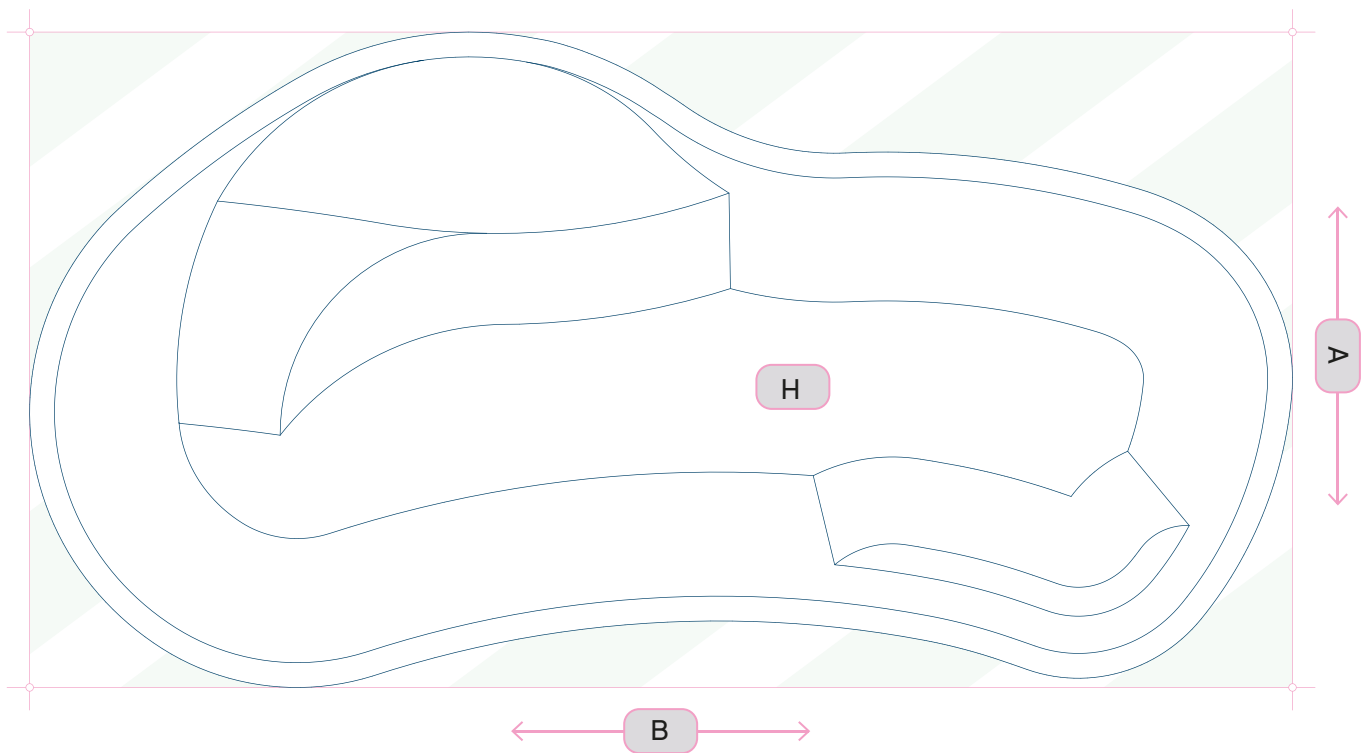



BD-08

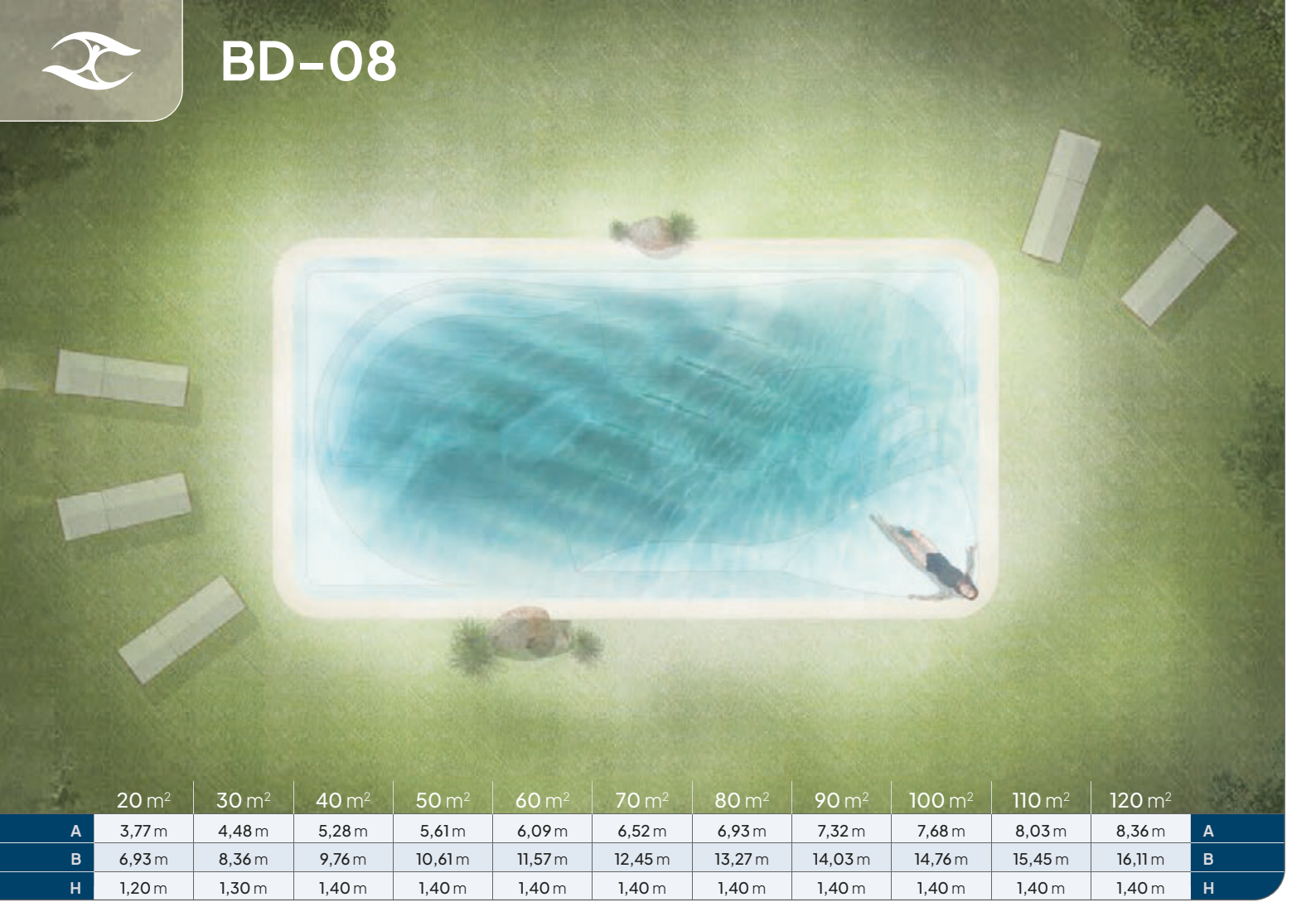

	20 m ²	30 m ²	40 m ²	50 m ²	60 m ²	70 m ²	80 m ²	90 m ²	100 m ²	110 m ²	120 m ²	
A	3,77 m	4,48 m	5,28 m	5,61 m	6,09 m	6,52 m	6,93 m	7,32 m	7,68 m	8,03 m	8,36 m	A
B	6,93 m	8,36 m	9,76 m	10,61 m	11,57 m	12,45 m	13,27 m	14,03 m	14,76 m	15,45 m	16,11 m	B
H	1,20 m	1,30 m	1,40 m	1,40 m	1,40 m	1,40 m	1,40 m	1,40 m	1,40 m	1,40 m	1,40 m	H

* 30 cm border included | 30 cm di bordo incluso | Borde de 30 cm incluido | Bordure de 30 cm incluse | Inklusive 30 cm Rand

BD-08

| 50 | 60 | 70 |

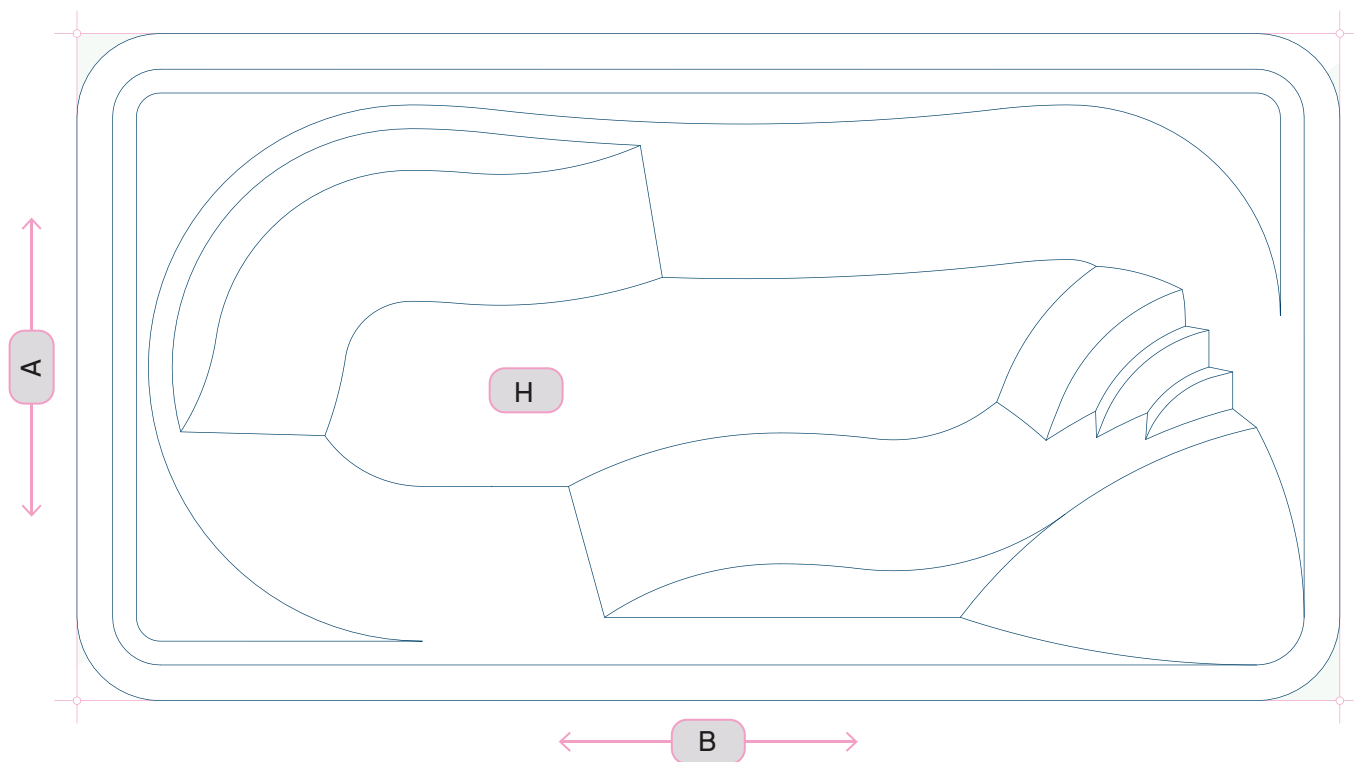

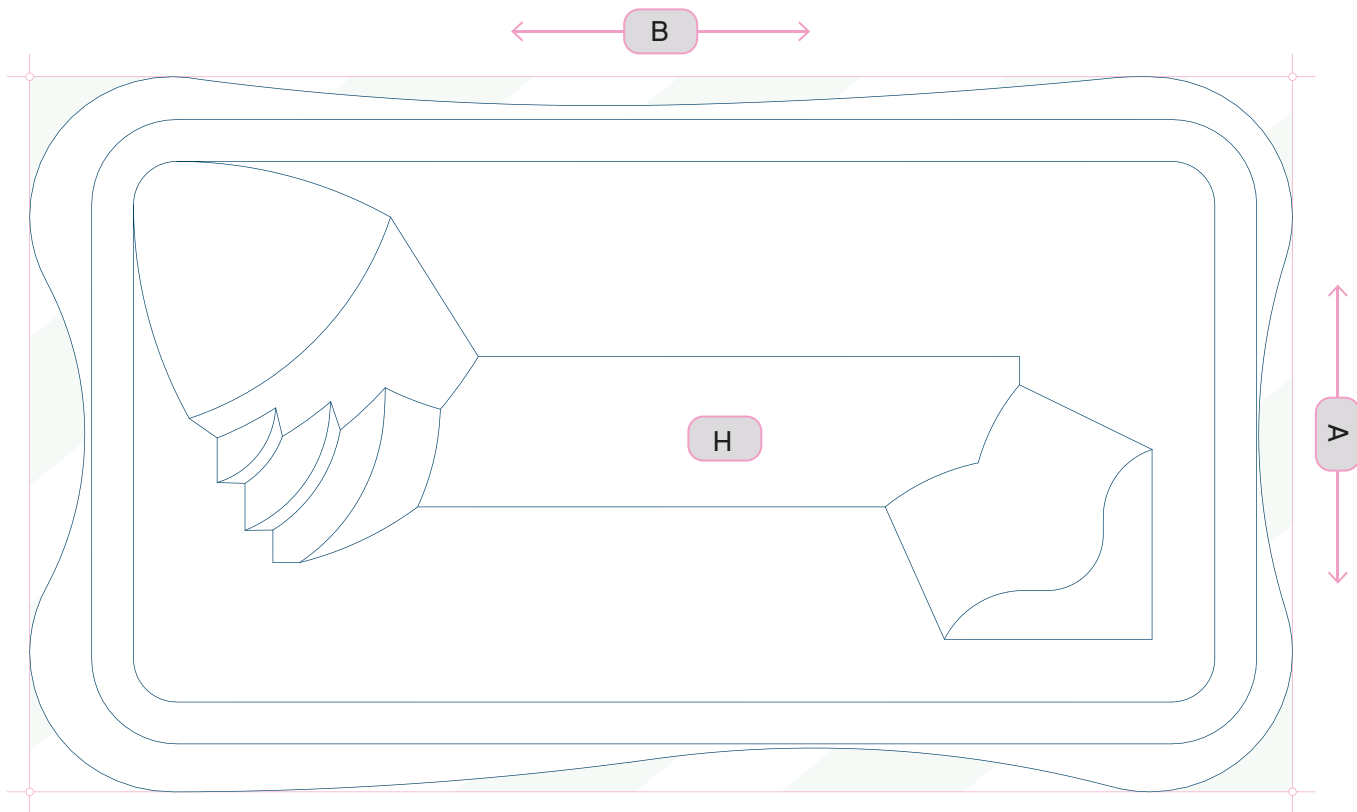

|20|30|40|

BD-08

|80|90|100|110|120|

BD-08

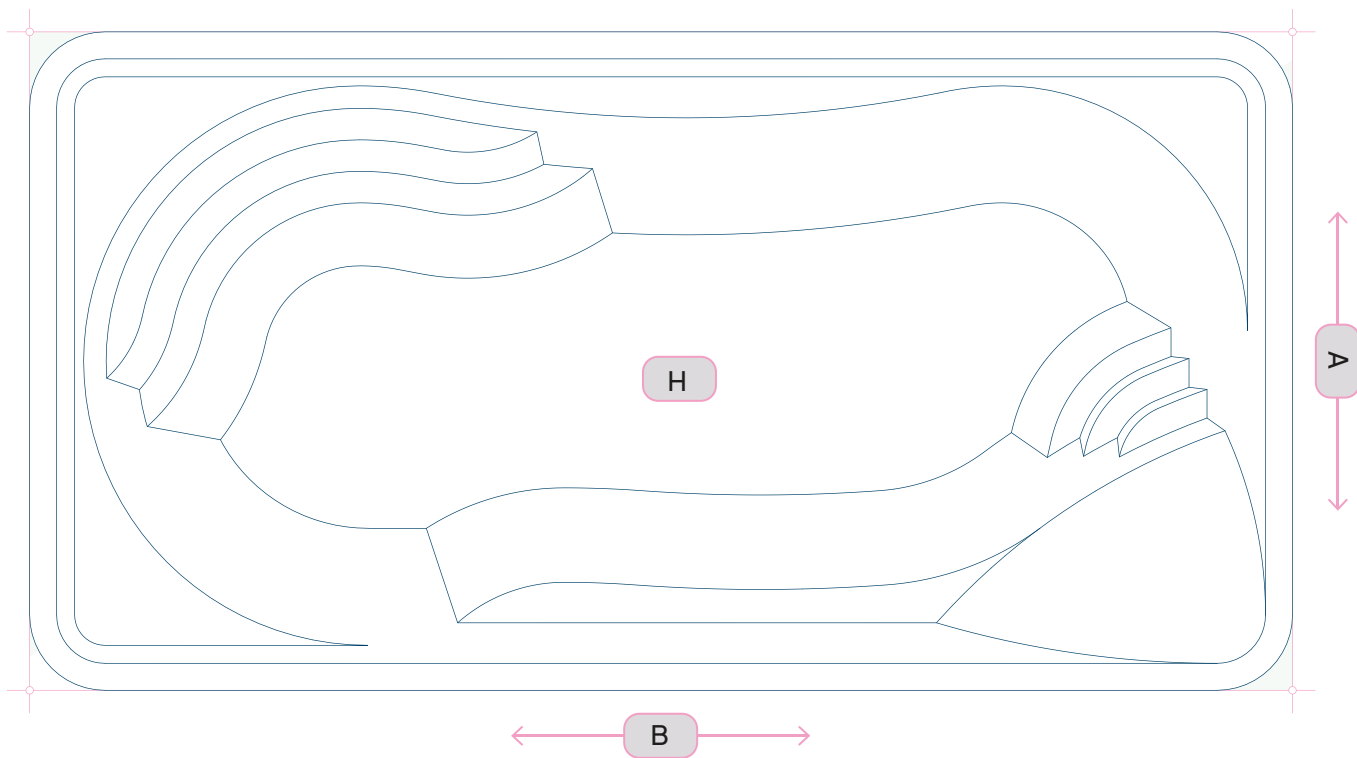



BD-09

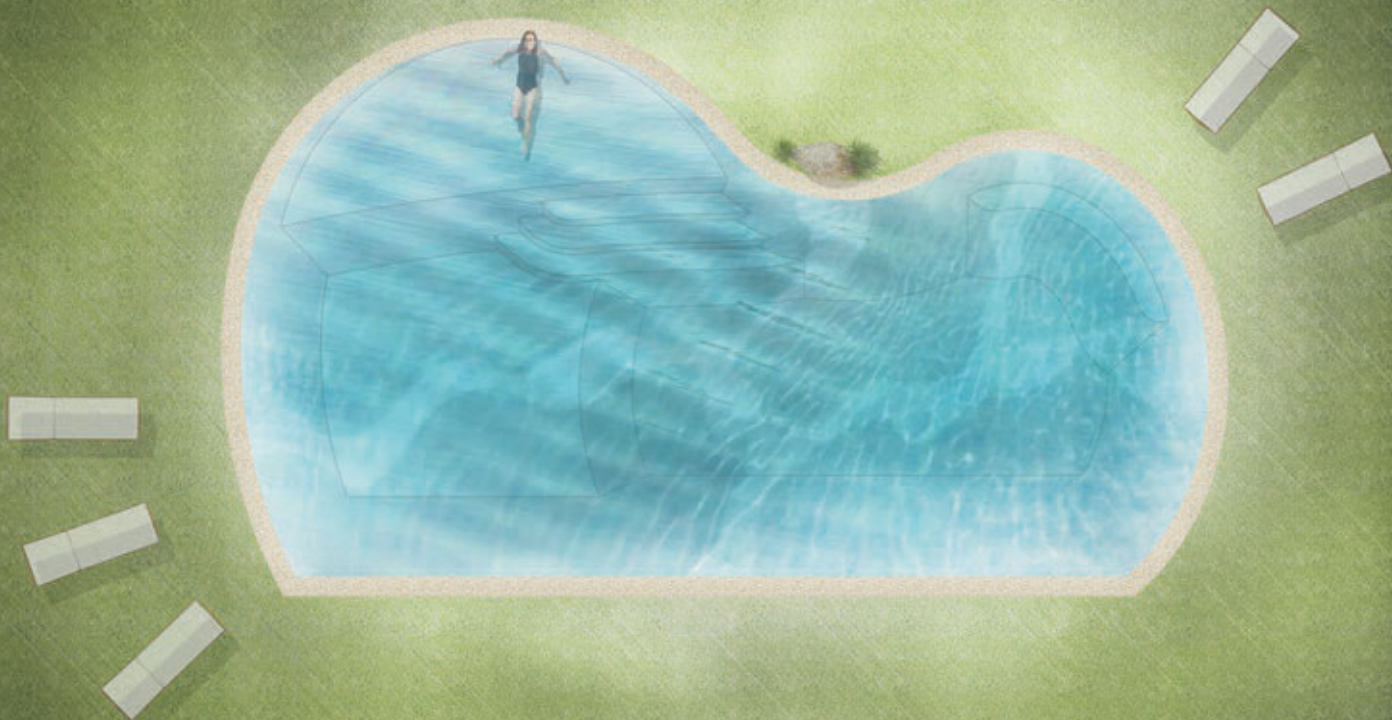

	20 m ²	30 m ²	40 m ²	50 m ²	60 m ²	70 m ²	80 m ²	90 m ²	100 m ²	110 m ²	120 m ²	
A	4,15 m	4,95 m	5,08 m	6,15 m	6,68 m	7,57 m	8,05 m	8,50 m	8,94 m	9,34 m	9,72 m	A
B	7,29 m	8,79 m	9,56 m	11,32 m	12,35 m	13,16 m	14,02 m	14,84 m	15,62 m	16,35 m	17,05 m	B
H	1,20 m	1,30 m	1,40 m	1,40 m	1,40 m	1,40 m	1,40 m	1,40 m	1,40 m	1,40 m	1,40 m	H

* 30 cm border included | 30 cm di bordo incluso | Borde de 30 cm incluido | Bordure de 30 cm incluse | Inklusive 30 cm Rand

BD-09 | 40 | 50 | 60 |

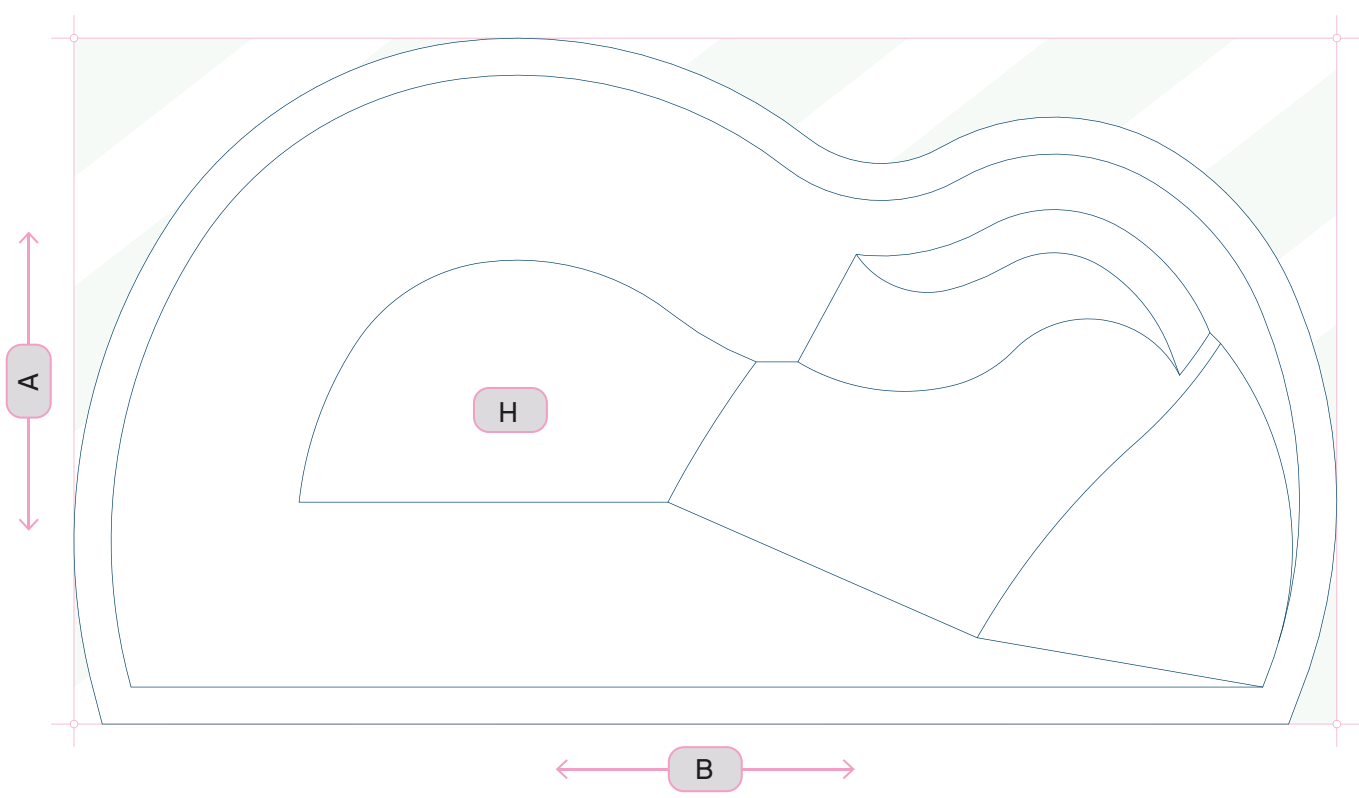

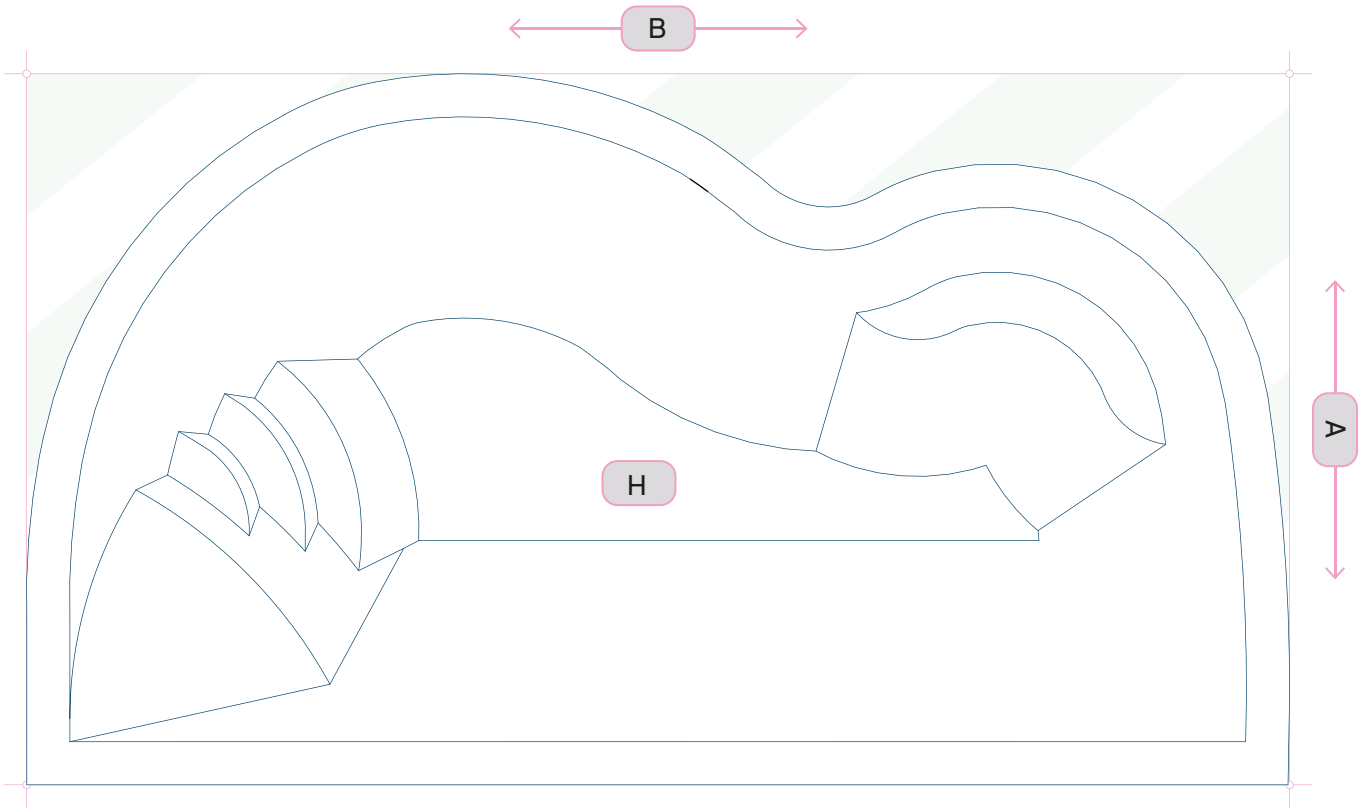

|20|30|

BD-09

|70|80|90|100|110|120|

BD-09

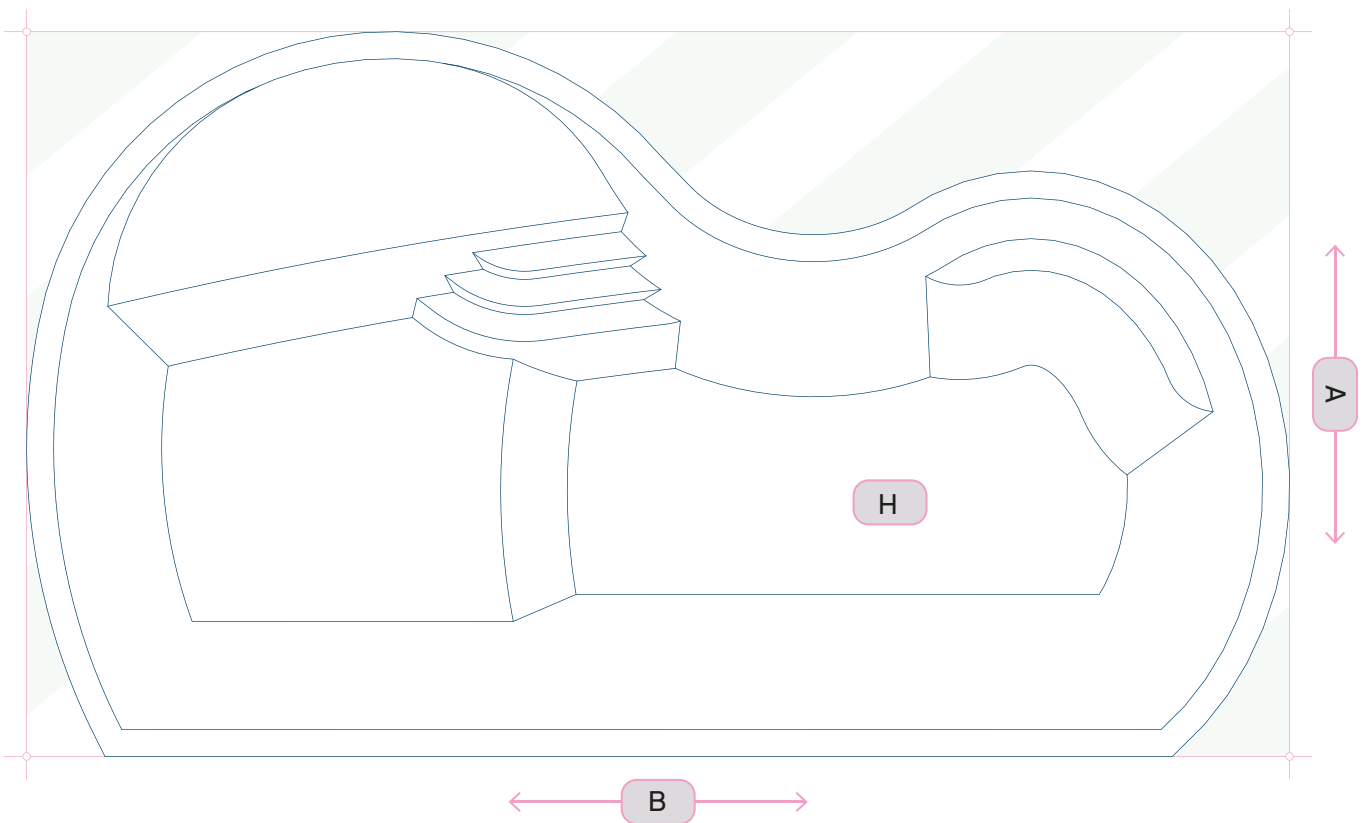



BD-10

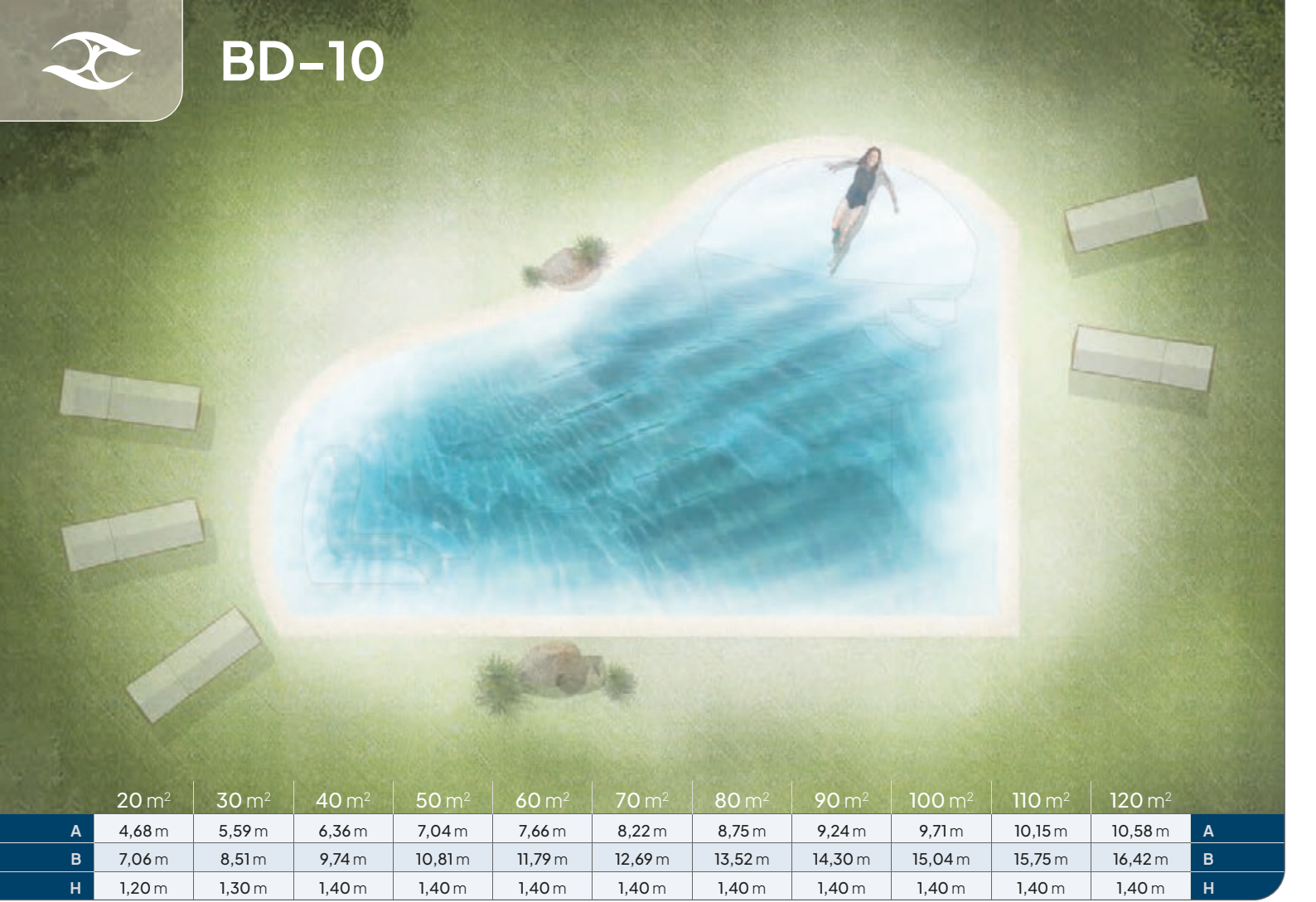

	20 m ²	30 m ²	40 m ²	50 m ²	60 m ²	70 m ²	80 m ²	90 m ²	100 m ²	110 m ²	120 m ²	
A	4,68 m	5,59 m	6,36 m	7,04 m	7,66 m	8,22 m	8,75 m	9,24 m	9,71 m	10,15 m	10,58 m	A
B	7,06 m	8,51 m	9,74 m	10,81 m	11,79 m	12,69 m	13,52 m	14,30 m	15,04 m	15,75 m	16,42 m	B
H	1,20 m	1,30 m	1,40 m	1,40 m	1,40 m	1,40 m	1,40 m	1,40 m	1,40 m	1,40 m	1,40 m	H

* 30 cm border included | 30 cm di bordo incluso | Borde de 30 cm incluido | Bordure de 30 cm incluse | Inklusive 30 cm Rand

BD-10 | 40 | 50 | 60 |

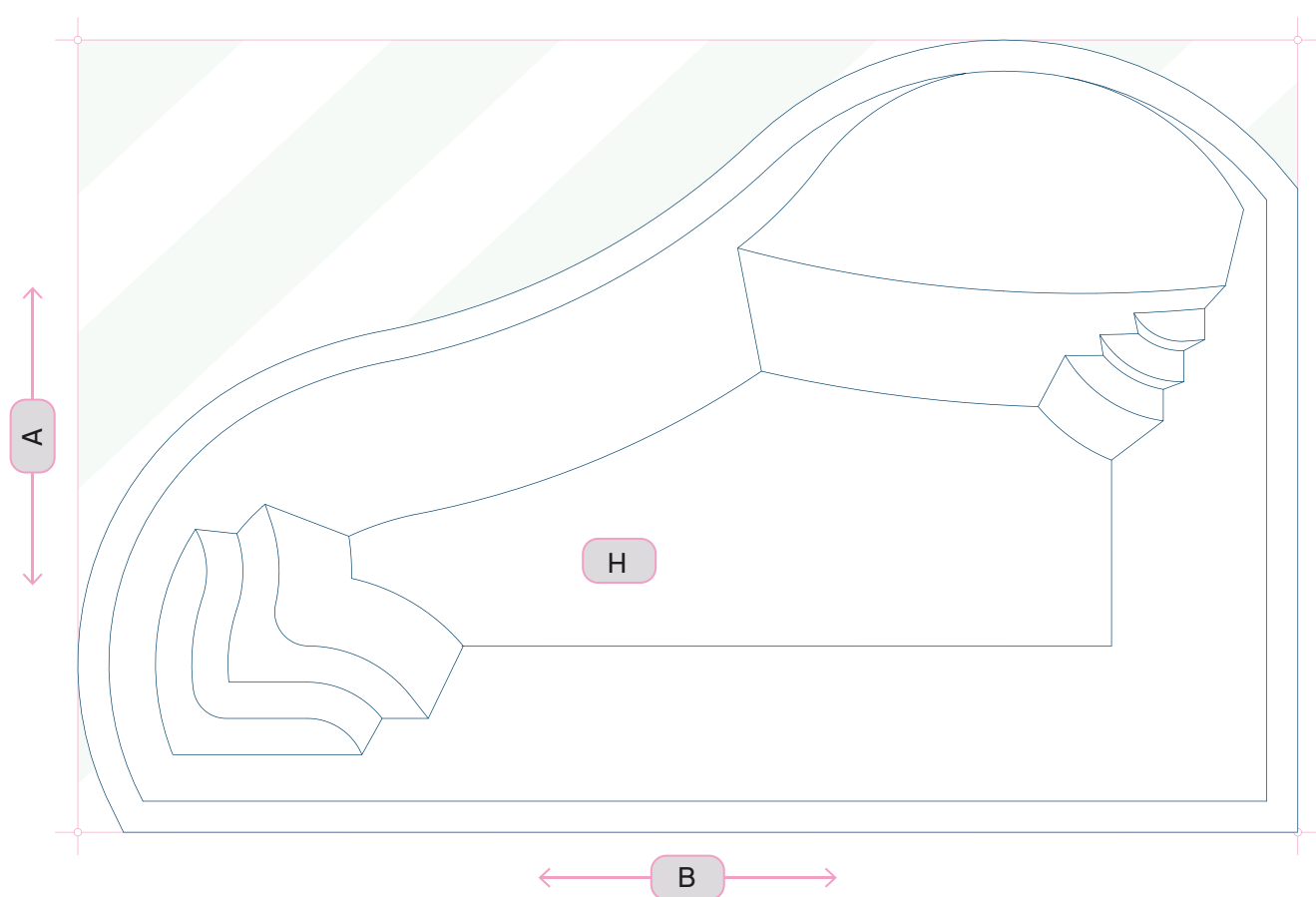

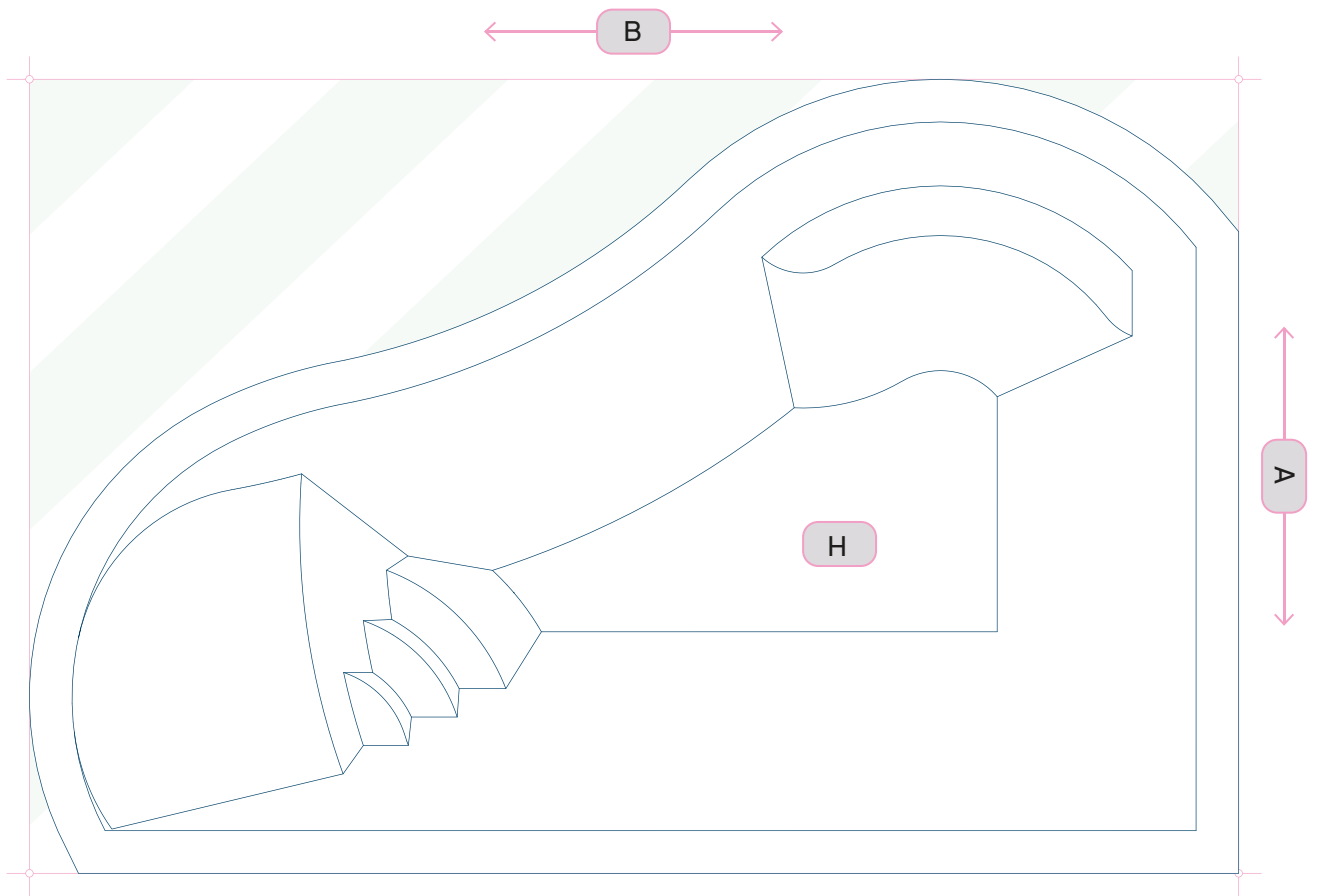

|20|30|

BD-10

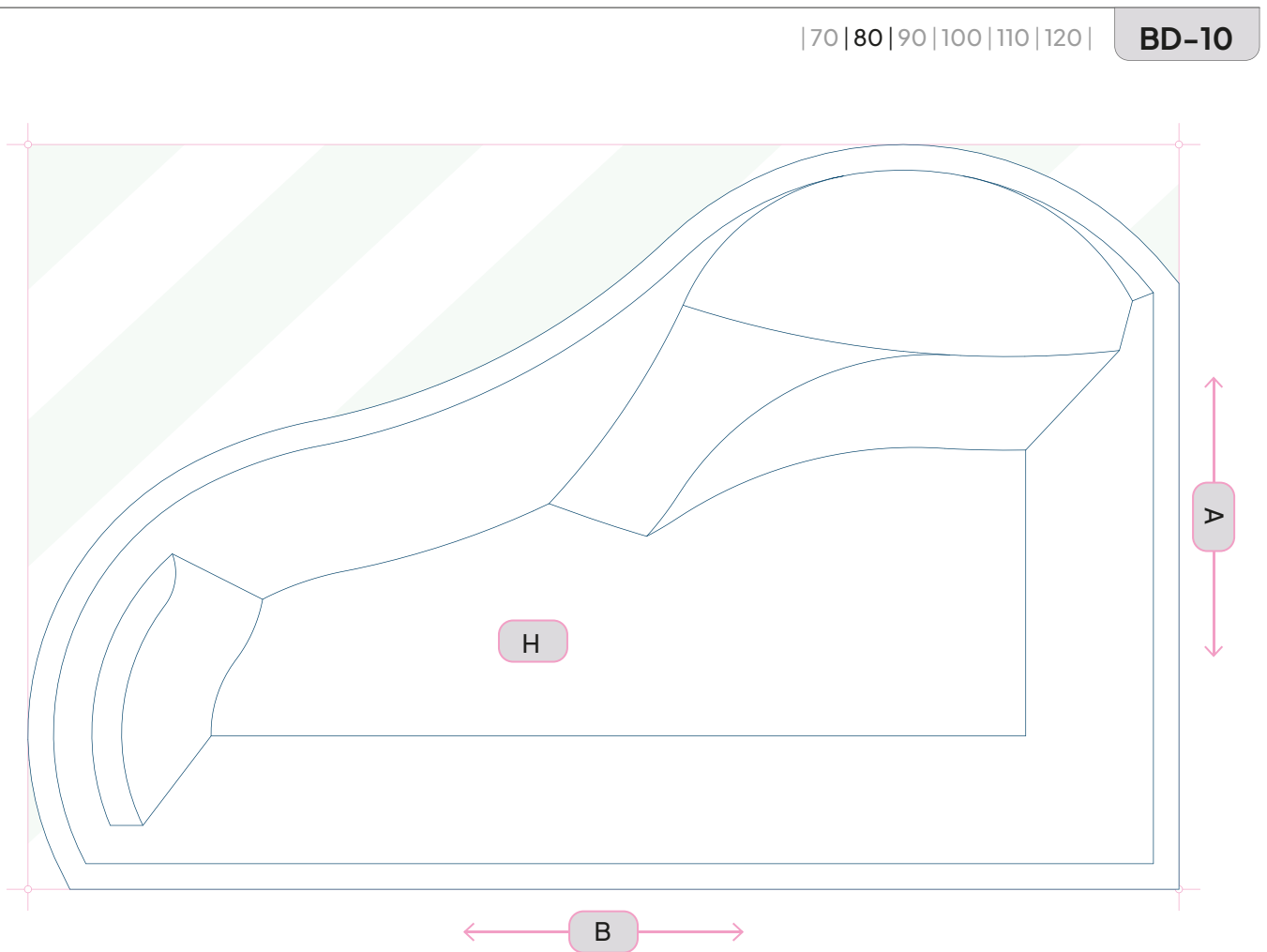

BD-10



BD-11

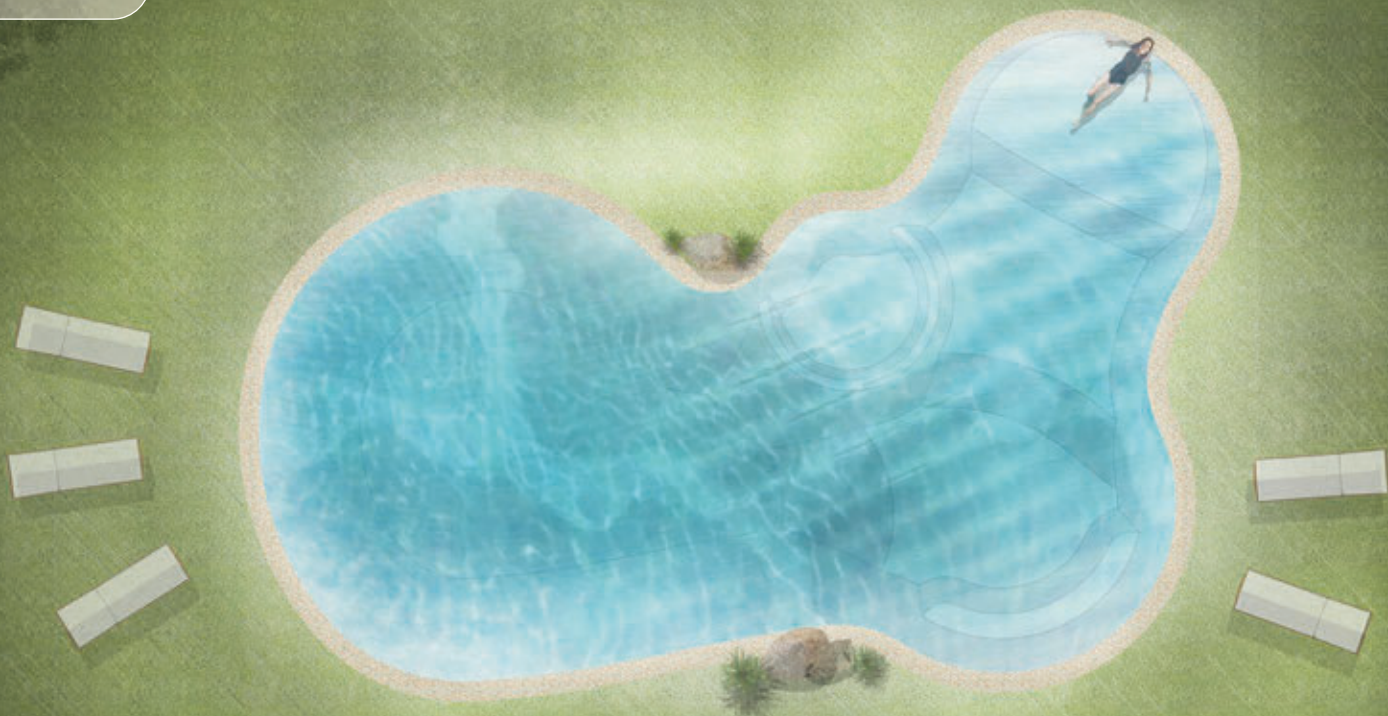

	20 m ²	30 m ²	40 m ²	50 m ²	60 m ²	70 m ²	80 m ²	90 m ²	100 m ²	110 m ²	120 m ²	
A	5,11 m	6,12 m	6,89 m	7,63 m	8,30 m	8,92 m	9,50 m	10,04 m	10,55 m	11,03 m	11,50 m	A
B	6,93 m	8,35 m	10,03 m	11,14 m	12,14 m	13,07 m	13,93 m	14,74 m	15,50 m	16,23 m	16,92 m	B
H	1,20 m	1,30 m	1,40 m	1,40 m	1,40 m	1,40 m	1,40 m	1,40 m	1,40 m	1,40 m	1,40 m	H

* 30 cm border included | 30 cm di bordo incluso | Borde de 30 cm incluido | Bordure de 30 cm incluse | Inklusive 30 cm Rand

BD-11

| 40 | 50 | 60 |

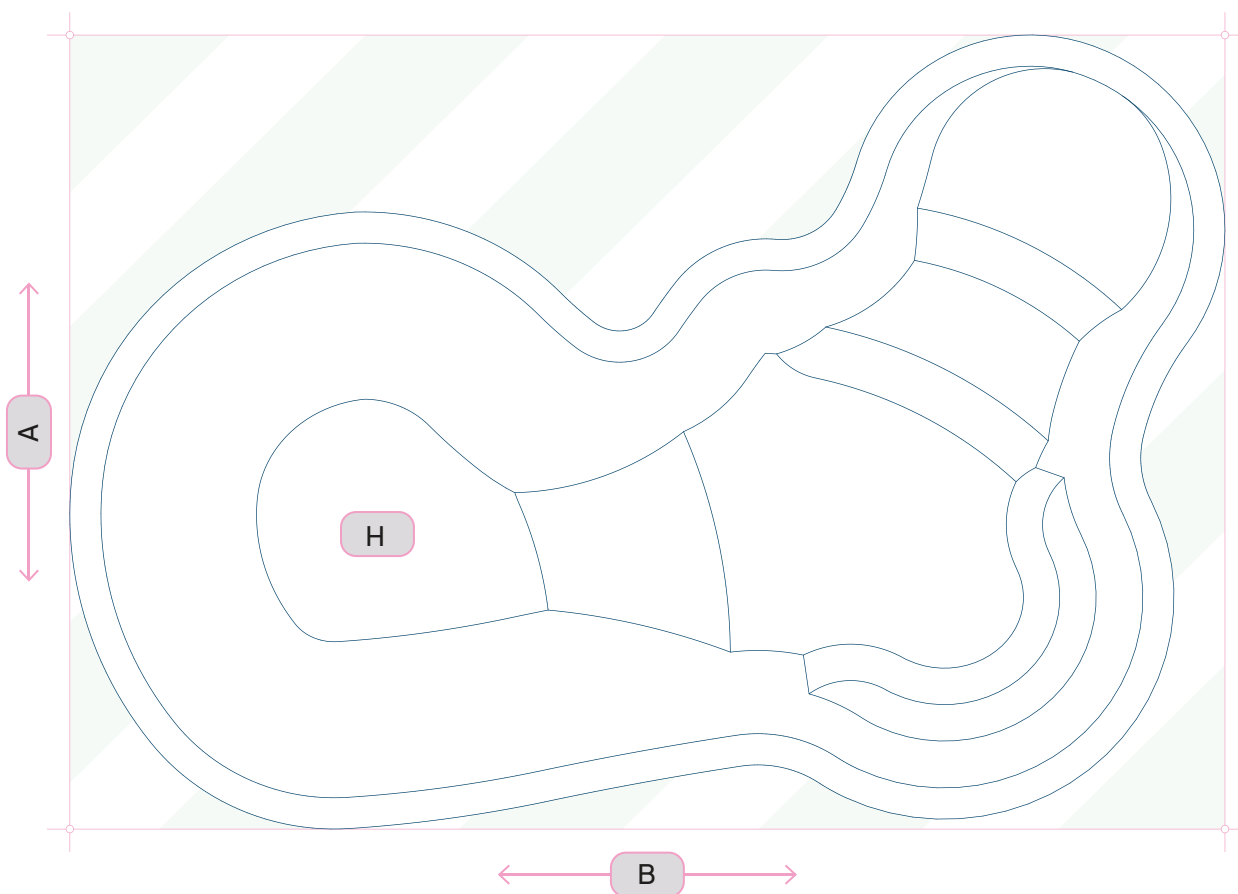

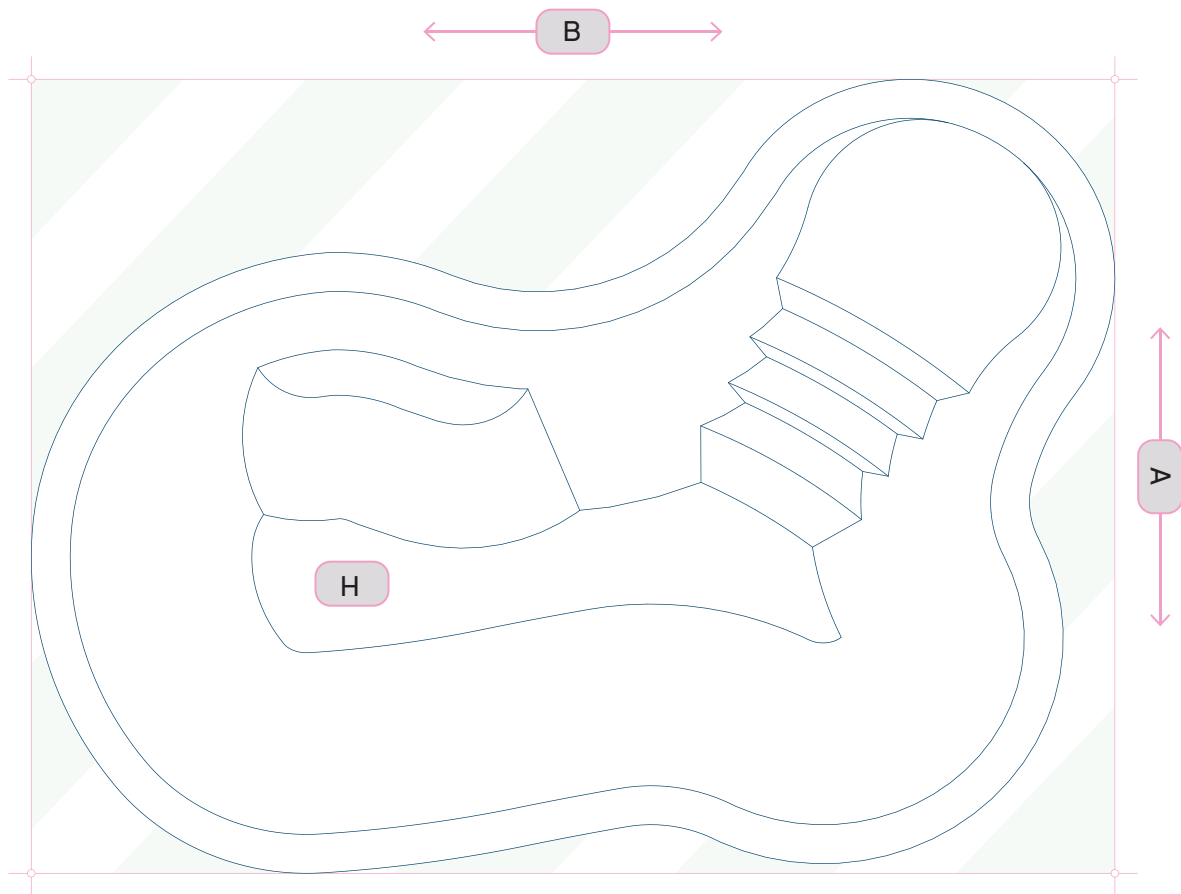

| 20 | 30 |

BD-11

| 70 | 80 | 90 | 100 | 110 | 120 |

BD-11

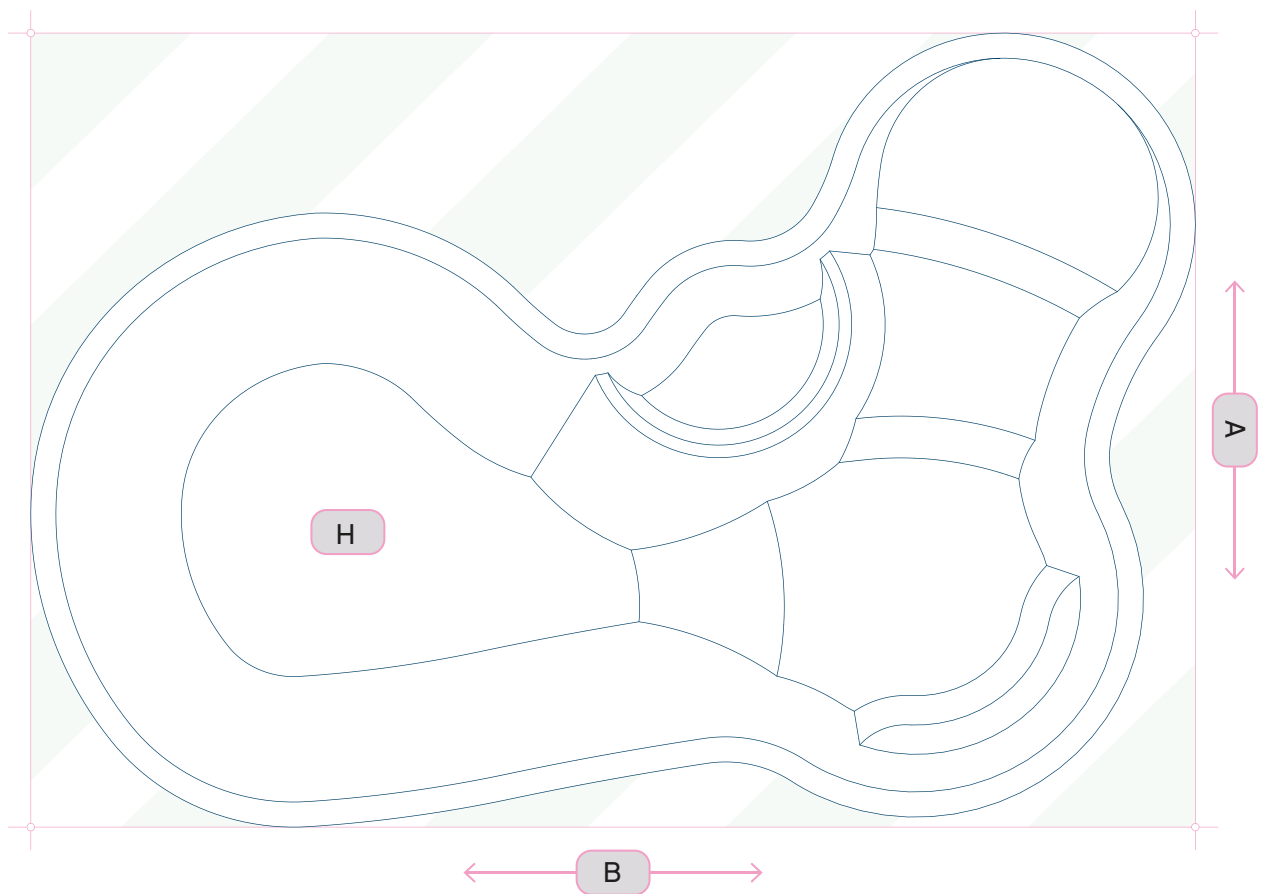



BD-12

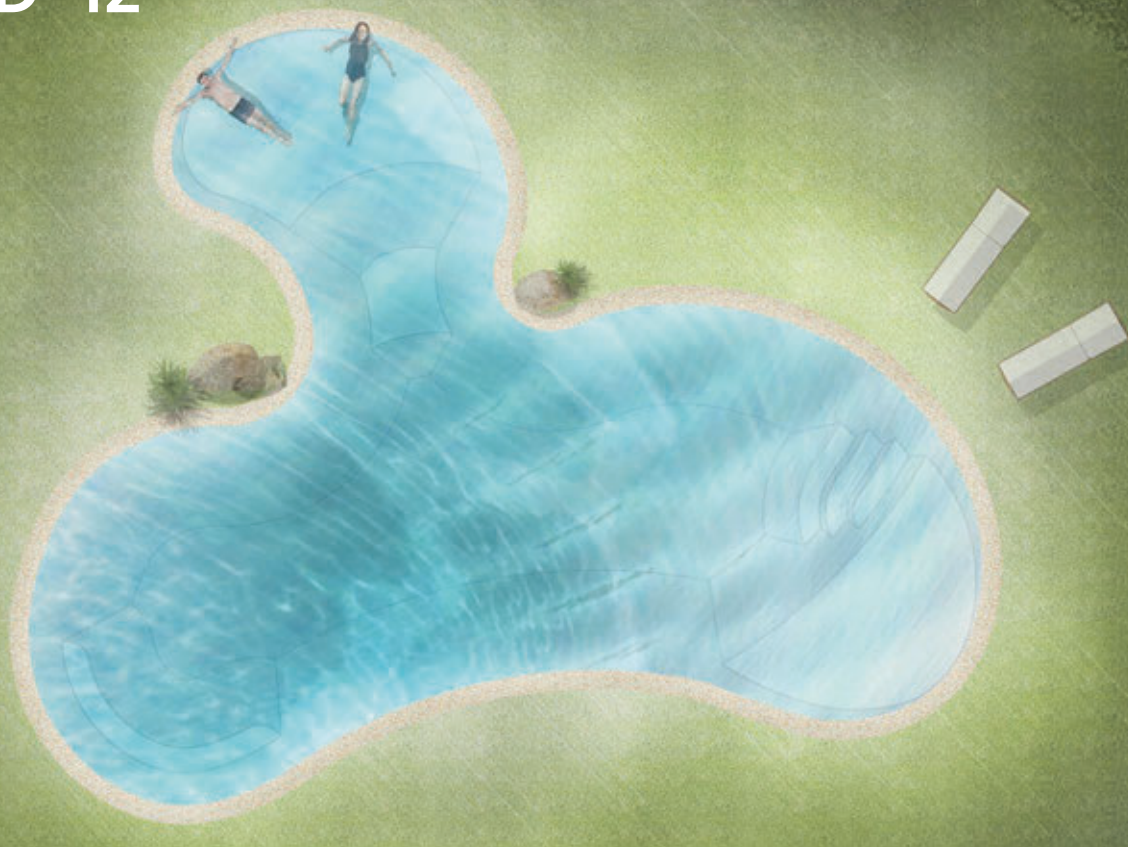

	20 m ²	30 m ²	40 m ²	50 m ²	60 m ²	70 m ²	80 m ²	90 m ²	100 m ²	110 m ²	120 m ²	
A	X	X	X	9,32 m	10,15 m	10,92 m	11,63 m	12,30 m	12,93 m	13,54 m	14,11 m	A
B	X	X	X	11,18 m	12,19 m	13,12 m	13,98 m	14,80 m	15,56 m	16,29 m	16,99 m	B
H	X	X	X	1,40 m	1,40 m	1,40 m	1,40 m	1,40 m	1,40 m	1,40 m	1,40 m	H

* 30 cm border included | 30 cm di bordo incluso | Borde de 30 cm incluido | Bordure de 30 cm incluse | Inklusive 30 cm Rand

BD-12

|70|80|90|

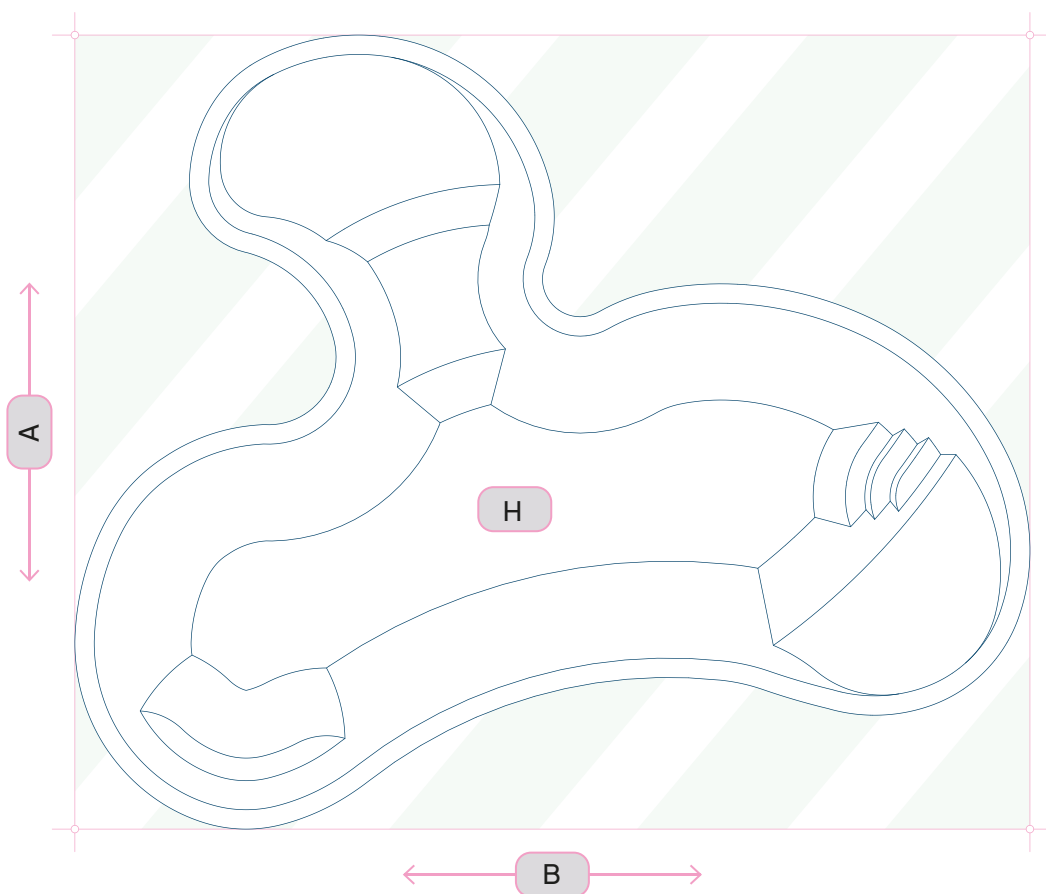

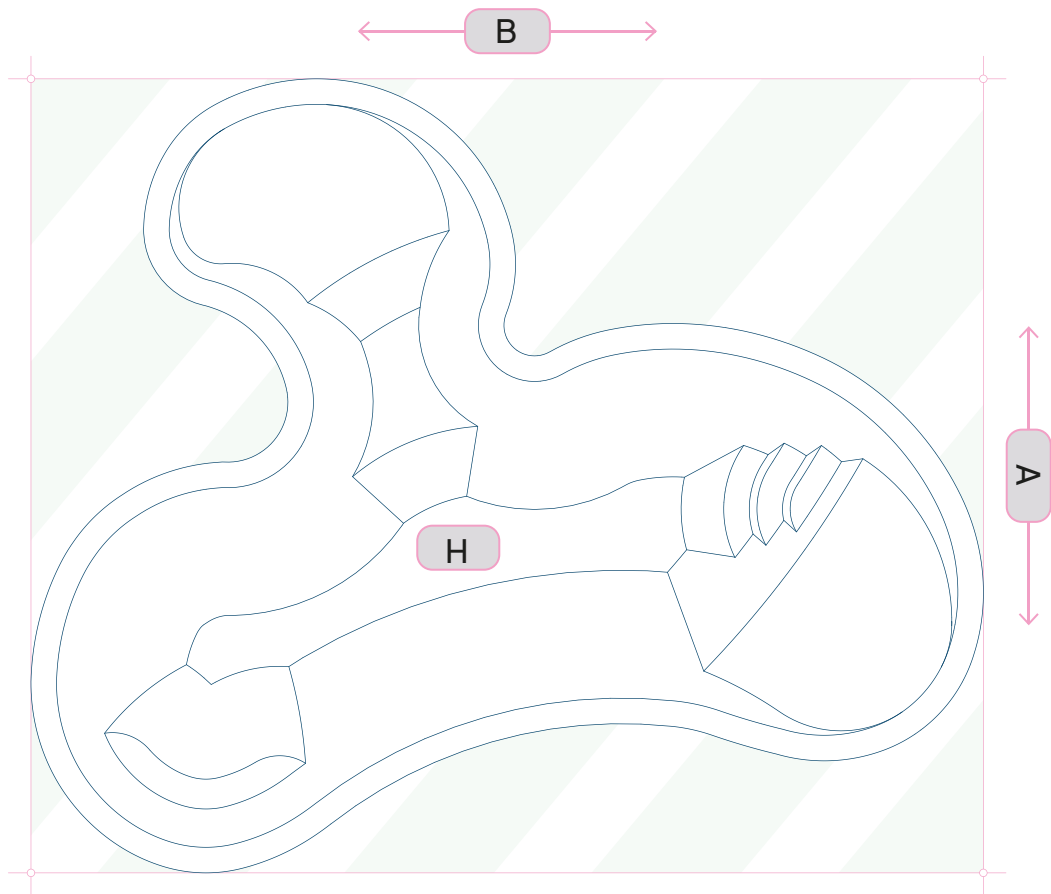

|50|60|

BD-12

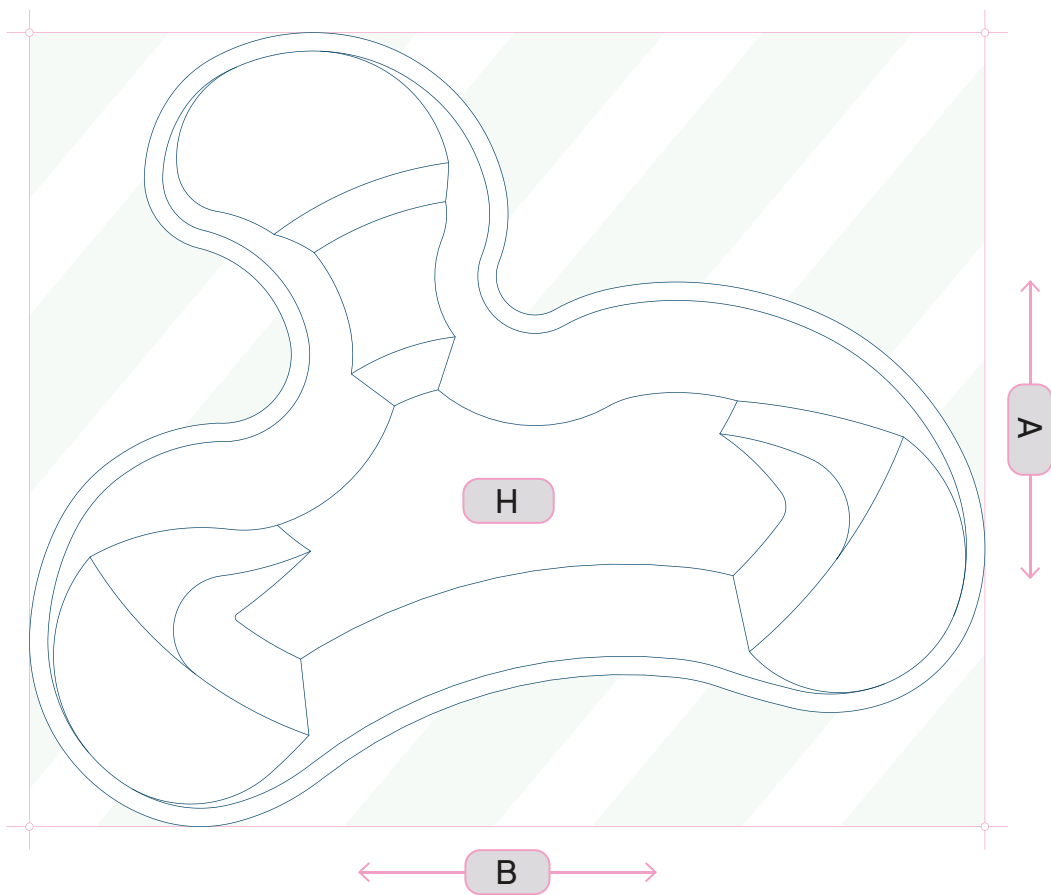

|100|110|120|

BD-12

Bio.design natural finishes

Finiture naturali | Acabados naturales | Finitions naturelles | Natürliche Oberflächen

[EN]

Expertly mixed natural quartz stone in different colours and grain sizes to make each Bio.design creation unique.

[IT]

Pietra di quarzo naturale sapientemente miscelata in diverse colorazioni e granulometrie per rendere unica ogni realizzazione Bio.design.

[ES]

Piedra de cuarzo natural hábilmente mezclada en diferentes colores y tamaños de grano para que cada creación Bio.design sea única.

[FR]

Des pierres de quartz naturel habilement mélangées dans différentes couleurs et granulométries pour rendre chaque création Bio.design unique.

[DE]

Natürlicher Quarzstein, der fachmännisch in verschiedenen Farben und Korngrößen gemischt wird, um jede Bio.design-Kreation einzigartig zu machen.

Final coating

Rivestimento di finitura | Capa de acabado | Couche de finition | Endbeschichtung



Mylago Gold
(Standard coating)



Mylago Classic
(Standard coating)

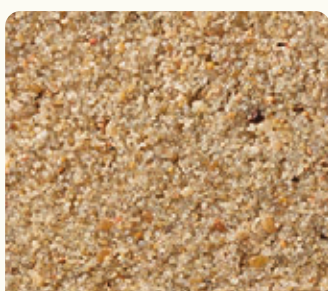

Waikiki
(Option fine sand coating)



50% Green Olivina 50% White Coral
Smeraldo
(Option fine sand coating)



50% Waikiki 50% White coral
Goa
(Option fine sand coating)

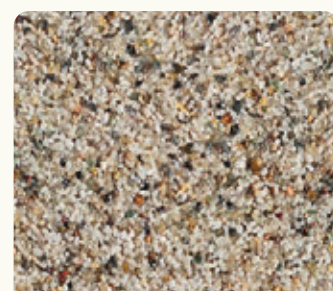

Termapond
(Option fine sand coating)

Expansion joints

Giunti di dilatazione | Juntas de dilatación | Joint de dilatation | Kies und dehnfugen

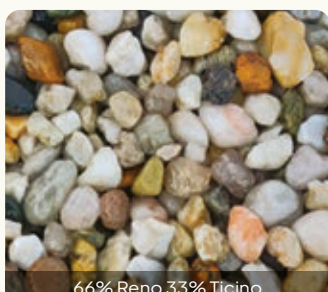

66% Reno 33% Ticino

Duna

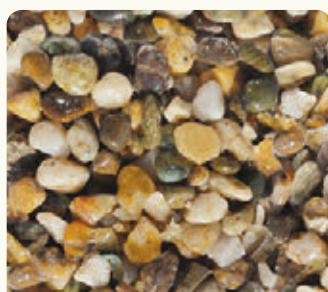

Ticino



Botticino



Verde Alpi

[EN]

Bio.design pools are protected by the Microban®, SilverShield® antibacterial technology. Microban® is a valuable and efficient tool in the fight against bacterial growth.

[IT]

Le piscine Bio.design sono protette dalla tecnologia antibatterica Microban® SilverShield®. Uno strumento prezioso ed efficiente nella lotta contro la proliferazione dei batteri.

[ES]

Las piscinas de Bio.design están protegidas por tecnología antibacteriana Microban® SilverShield®. Microban® constituye una herramienta valiosa y eficaz en la lucha contra el crecimiento bacteriano.

[FR]

Les piscines Bio.design sont protégées par la technologie antibactérienne Microban® SilverShield®. Microban® constitue un outil précieux et efficace dans la lutte contre la croissance bactérienne.

[DE]

Bio.design-Pools werden durch die antibakterielle Technologie SilverShield® von Microban® geschützt. Microban® stellt ein wertvolles und wirksames Instrument zum Kampf gegen das Bakterienwachstum dar.



Headquarters and warehouse

BIODESIGN S.p.A.

Via Enrico Fermi, 8 • 35030 • Rubano • PD • Italy

Tel. +39.049.8862961 • Tel. +39.049.8863067

Registered office

BIODESIGN S.p.A.

Galleria San Babila 4/B • 20122 • Milano • Italy

www.bio.design

info@bio.design